

# KV-20TR22/20TS27

RM-781 RM-783

## SERVICE MANUAL

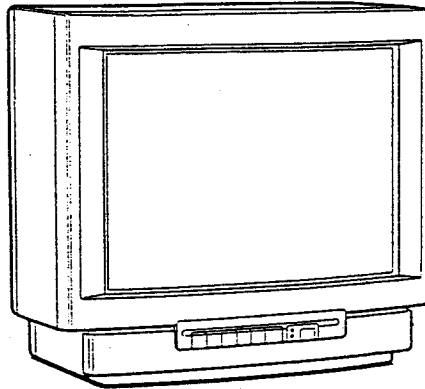

*US Model*

*KV-20TR22*

*Chassis No. SCC-D37G-A*

*KV-20TS27*

*Chassis No. SCC-D37H-A*

*Canadian Model*

*KV-20TS27*

*Chassis No. SCC-D36D-A*

## P-3B CHASSIS

MODELS OF THE SAME SERIES	
KV-20TR22/20TS27	KV-20TR10
KV-20TS20	KV-20TR12
KV-20TS24	

### SPECIFICATIONS

<b>Television system</b>	American TV standards
<b>Channel coverage</b>	VHF: 2 - 13 UHF: 14 - 69
<b>Picture tube</b>	Cable TV: 1 - 125 Microblack™ Trinitron tube 20-inch picture measured diagonally 21-inch picture tube measured diagonally
<b>Antenna</b>	75-ohm external antenna terminal for VHF/UHF
<b>Input</b>	VIDEO INPUT (phono jacks) Video: 1Vp-p, 75-ohms unbalanced, sync negative Audio: 500 mVrms (100% modulation) Impedance: 10 kilohms
<b>Output</b> (KV-20TS27 only)	AUDIO OUTPUT (VARIABLE) (phono jacks) More than 408 mVrms at the maximum volume setting (variable) (100% modulation)
<b>Power requirements</b>	120 V AC, 60Hz
<b>Power consumption</b>	125 W (Max.) 5 W (in standby condition)
<b>Dimensions</b>	527.0 x 488.5 x 482.0 mm(W/H/D) (20 3/4" x 19 1/4" x 19")
<b>Weight</b>	KV-20TS27: 23.4 Kg (51 lbs 10 oz) KV-20TR22: 23.1 Kg (50 lbs 15 oz)

### Supplied accessories

Model	Remote Commander
KV-20TS27	RM-783 (1) with 2 size AA (R6) batteries
KV-20TR22	RM-781 (1)

All Models	VHF/UHF telescopic dipole antenna (1)*
	Antenna connector (1)

\* Except Canada

<b>Optional accessories</b>	U/V mixer EAC-66
	Connecting cable
	VMC-606/607M
	VMC-810/820S
	RK-74A

Designs and specifications are subject to change without notice.



TRINITRON® COLOR TV  
**SONY®**

**TABLE OF CONTENTS**

<u>Section</u>	<u>Title</u>	<u>Page</u>	<u>Section</u>	<u>Title</u>	<u>Page</u>
1.	GENERAL		4.	SAFETY RELATED ADJUSTMENTS .....	14
1-1.	Location of Controls .....	4	5.	CIRCUIT ADJUSTMENTS	
1-2.	Presetting TV Channels .....	5	5-1.	A Board Adjustments .....	16
1-3.	Using the TIMER/BLOCK Functions .....	6	6.	DIAGRAMS	
1-4.	Other Useful Features .....	8	6-1.	Circuit Boards Location .....	18
2.	DISASSEMBLY		6-2.	Printed Wiring Boards and Schematic Diagrams .....	18
2-1.	Rear Cover Removal .....	9	6-3.	Semiconductors .....	31
2-2.	Picture Tube Removal .....	9	7.	EXPLODED VIEWS	
2-3.	Service Position .....	10	7-1.	Chassis .....	32
3.	SET-UP ADJUSTMENTS		7-2.	Picture Tube .....	33
3-1.	Beam Landing .....	11	8.	ELECTRICAL PARTS LIST .....	34
3-2.	Convergence .....	12			
3-3.	Focus (G4) .....	13			
3-4.	SUB BRT (RV706) .....	13			
3-5.	White Balance .....	13			

**WARNING !!**

AN ISOLATION TRANSFORMER SHOULD BE USED DURING ANY SERVICE TO AVOID POSSIBLE SHOCK HAZARD, BECAUSE OF LIVE CHASSIS. THE CHASSIS OF THIS RECEIVER IS DIRECTLY CONNECTED TO THE AC POWER LINE.

**SAFETY-RELATED COMPONENT WARNING !!**

COMPONENTS IDENTIFIED BY SHADING AND MARK  ON THE SCHEMATIC DIAGRAMS, EXPLODED VIEWS AND IN THE PARTS LIST ARE CRITICAL TO SAFE OPERATION. REPLACE THESE COMPONENTS WITH SONY PARTS WHOSE PART NUMBERS APPEAR AS SHOWN IN THIS MANUAL OR IN SUPPLEMENTS PUBLISHED BY SONY. CIRCUIT ADJUSTMENTS THAT ARE CRITICAL TO SAFE OPERATION ARE IDENTIFIED IN THIS MANUAL. FOLLOW THESE PROCEDURES WHENEVER CRITICAL COMPONENTS ARE REPLACED OR IMPROPER OPERATION IS SUSPECTED.

**ATTENTION!!**

AFIN D'EVITER TOUT RISQUE D'ELECTROCUTION PROVENANT D'UN CHÂSSIS SOUS TENSION, UN TRANSFORMATEUR D'ISOLEMENT DOIT ETRE UTILISÉ LORS DE TOUT DÉPANNAGE. LE CHÂSSIS DE CE RÉCEPTEUR EST DIRECTEMENT RACCORDÉ À L'ALIMENTATION SECTEUR.

**ATTENTION AUX COMPOSANTS RELATIFS À LA SÉCURITÉ!!**

LES COMPOSANTS IDENTIFIÉS PAR UNE TRAME ET PAR UNE MARQUE  SUR LES SCHÉMAS DE PRINCIPE, LES VUES EXPLOSÉES ET LES LISTES DE PIÈCES SONT D'UNE IMPORTANCE CRITIQUE POUR LA SÉCURITÉ DU FONCTIONNEMENT. NE LES REMPLACER QUE PAR DES COMPOSANTS SONY DONT LE NUMÉRO DE PIÈCE EST INDIQUÉ DANS LE PRÉSENT MANUEL OU DANS DES SUPPLÉMENTS PUBLIÉS PAR SONY. LES RÉGLAGES DE CIRCUIT DONT L'IMPORTANCE EST CRITIQUE POUR LA SÉCURITÉ DU FONCTIONNEMENT SONT IDENTIFIÉS DANS LE PRÉSENT MANUEL. SUIVRE CES PROCÉDURES LORS DE CHAQUE REMPLACEMENT DE COMPOSANTS CRITIQUES, OU LORSQU'UN MAUVAIS FONCTIONNEMENT EST SUSPECTÉ.

**SAFETY CHECK-OUT**

(US Model only)

After correcting the original service problem, perform the following safety checks before releasing the set to the customer:

1. Check the area of your repair for unsoldered or poorly-soldered connections. Check the entire board surface for solder splashes and bridges.
2. Check the interboard wiring to ensure that no wires are "pinched" or contact high-wattage resistors.
3. Check that all control knobs, shields, covers, ground straps, and mounting hardware have been replaced. Be absolutely certain that you have replaced all the insulators.
4. Look for unauthorized replacement parts, particularly transistors, that were installed during a previous repair. Point them out to the customer and recommend their replacement.
5. Look for parts which, though functioning, show obvious signs of deterioration. Point them out to the customer and recommend their replacement.
6. Check the line cord for cracks and abrasion. Recommend the replacement of any such line cord to the customer.
7. Check the condition of the monopole antenna (if any).  
Make sure the end is not broken off, and has the plastic cap on it. Point out the danger of impalement on a broken antenna to the customer, and recommend the antenna's replacement.
8. Check the B+ and HV to see they are at the values specified. Make sure your instruments are accurate; be suspicious of your HV meter if sets always have low HV.
9. Check the antenna terminals, metal trim, "metallized" knobs, screws, and all other exposed metal parts for AC leakage. Check leakage as described below.

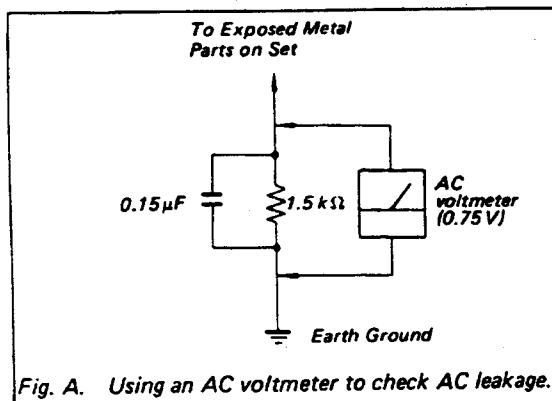
**LEAKAGE TEST**

The AC leakage from any exposed metal part to earth ground and from all exposed metal parts to any exposed metal part having a return to chassis, must not exceed 0.5 mA (500 microamperes). Leakage current can be measured by any one of three methods.

1. A commercial leakage tester, such as the Simpson 229 or RCA WT-540A. Follow the manufacturers' instructions to use these instruments.
2. A battery-operated AC milliammeter. The Data Precision 245 digital multimeter is suitable for this job.
3. Measuring the voltage drop across a resistor by means of a VOM or battery-operated AC voltmeter. The "limit" indication is 0.75 V, so analog meters must have an accurate low-voltage scale. The Simpson 250 and Sanwa SH-63Trd are examples of a passive VOM that is suitable. Nearly all battery operated digital multimeters that have a 2V AC range are suitable. (See Fig. A)

**HOW TO FIND A GOOD EARTH GROUND**

A cold-water pipe is guaranteed earth ground; the cover-plate retaining screw on most AC outlet boxes is also at earth ground. If the retaining screw is to be used as your earth-ground, verify that it is at ground by measuring the resistance between it and a cold-water pipe with an ohmmeter. The reading should be zero ohms. If a cold-water pipe is not accessible, connect a 60-100 watts trouble light (not a neon lamp) between the hot side of the receptacle and the retaining screw. Try both slots, if necessary, to locate the hot side of the line, the lamp should light at normal brilliance if the screw is at ground potential. (See Fig. B)

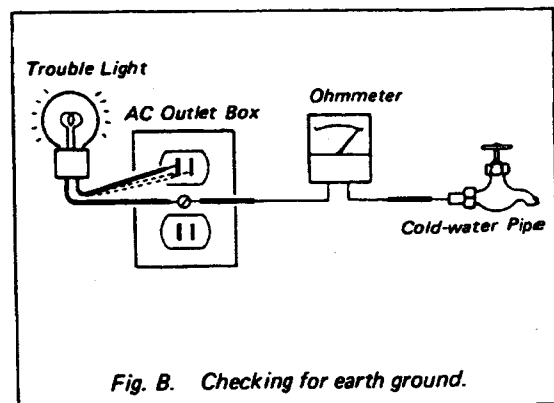

# 1-1. LOCATION OF CONTROLS

# SECTION 1 GENERAL

Front

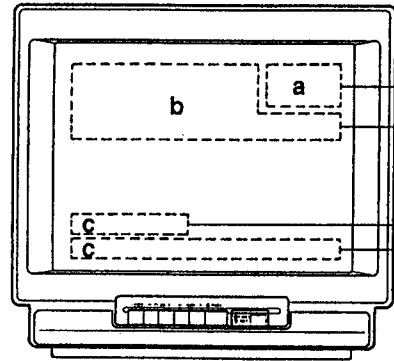

### On-Screen Displays

- a**
  - Channel numbers/Cable "C" display
  - MTS mode indication (KV-20TS27, KV-2137RS only)
  - "MUTING," "SLEEP" or "VIDEO" display
- b**
  - "AUTO PROGRAM," "TIMER" or "TIMER BLOCK" display
- c**
  - Bar display for volume or picture (HUE, COLOR, BRIGHTNESS, SHARPNESS) adjustment
  - Current time for TIMER/BLOCK

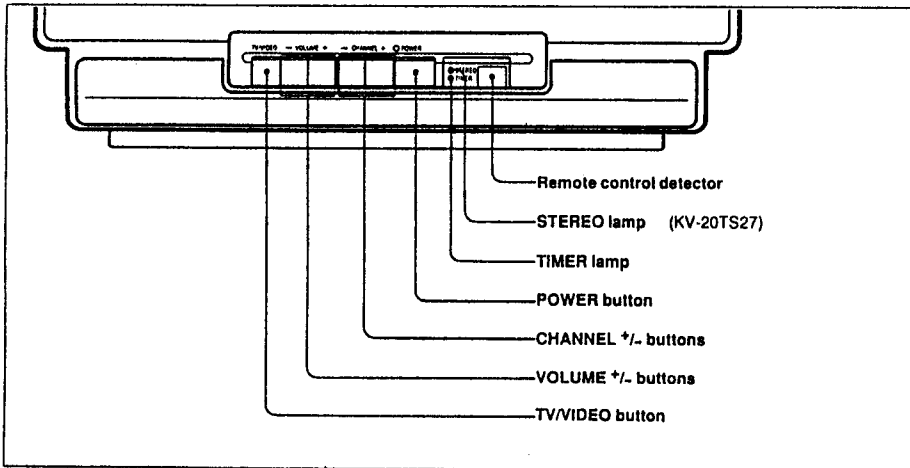

Rear

KV-20TR22  
KV-2127R

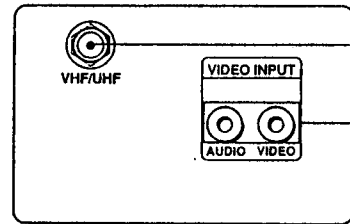

- VHF/UHF antenna terminal
- VIDEO INPUT jacks (AUDIO/VIDEO)

KV-20TS27  
KV-2137RS

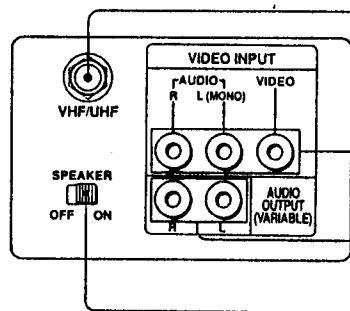

- VHF/UHF antenna terminal
- VIDEO INPUT jacks (AUDIO R, L (MONO) /VIDEO)
- AUDIO OUTPUT (VARIABLE) jacks
- SPEAKER ON/OFF switch



Remote Commander RM-781/RM-783

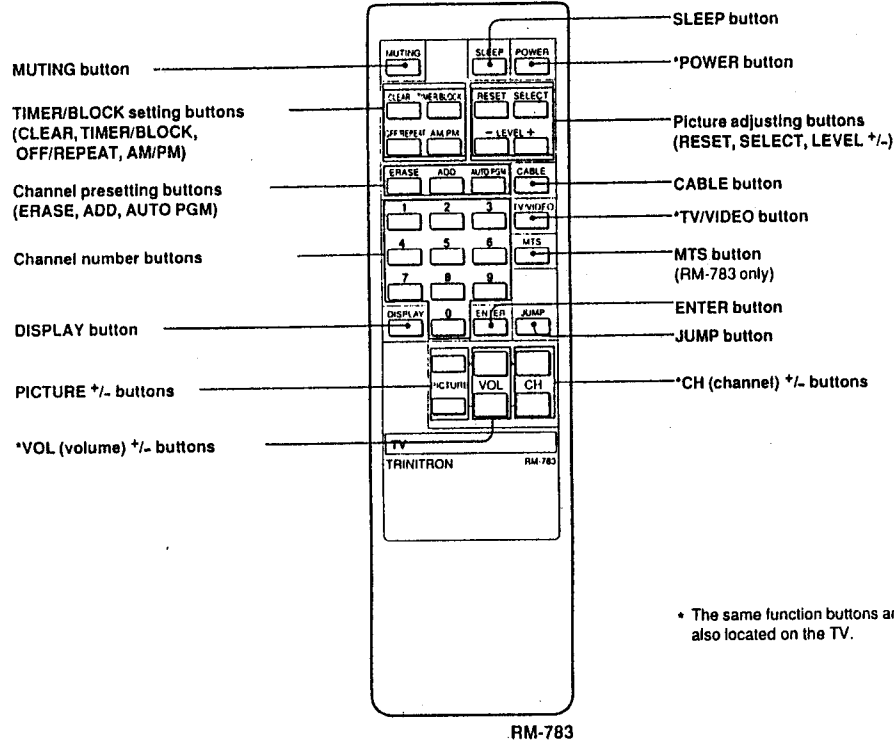

• The same function buttons are also located on the TV.

### Battery installation

**1** Open the lid.

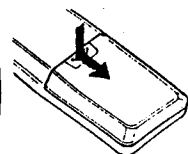

**2** Insert two size AA (R6) batteries in correct polarity.

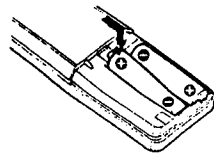

- With normal operation, batteries will last up to half a year. If the Commander does not operate properly, the batteries might be exhausted. Replace them with new ones.
- To avoid damage from possible battery leakage, remove the batteries when not using the Commander for an extended period.
- If a Remote Commander that is not recommended is used to operate this TV, or if the supplied Remote Commander is used to operate another TV, the TV may not operate properly.

## 1-2. PRESETTING TV CHANNELS

Use this feature to add channels to the channel scan memory.

### To Preset All Receivable Channels Automatically

KV-20TS27

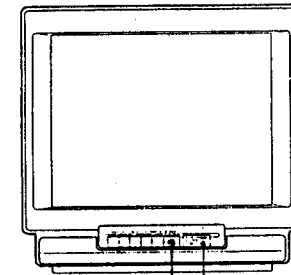

**1** Remote control detector

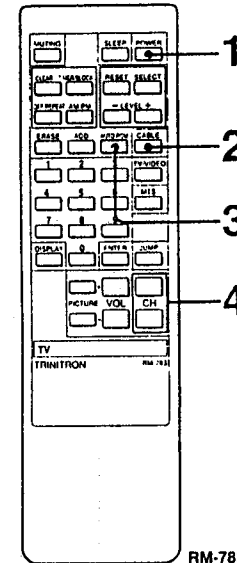

RM-783

- 1** Press POWER on the TV or the Remote Commander to turn the TV on.
- 2** Press CABLE so that the appropriate mode appears.

**3**

To preset VHF or UHF channels

**C3**

To preset cable TV channels

**NOTE**  
If "VIDEO" is displayed on the screen Press the TV/VIDEO button on the TV or on the Remote Commander so that a channel number appears.
- 3** Press AUTO PGM.

"AUTO PROGRAM" is displayed on the screen and receivable channels (other than the channels already preset) will be preset in numerical sequence. The channels previously preset remain in the TV's memory.  
When no more channels can be found, the programming stops and the lowest numbered channel is displayed.
- 4** To check or view preset channels Press CH +/-

#### Channels that can be received on this TV:

VHF: 2 - 13  
UHF: 14 - 69  
Cable: 1 - 125

To add channels that could not be preset automatically because their signal strength was too weak, or to erase unnecessary channels, follow the steps in "To preset only the desired channels" on the next page.

## To Preset Only Desired Channels or to Erase Unnecessary Channels

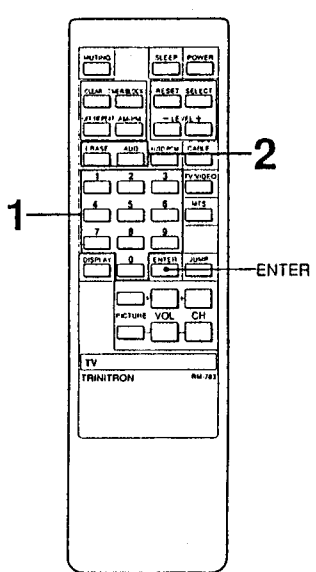

**1** Press the channel number button(s) and then press ENTER to select the channel you want to add or erase.

**2** To add channels - Press ADD.

A "+" appears before the number for a moment. This channel has now been added to the channel scan memory.

To erase channels - Press ERASE.

A "-" appears before the number for a moment. This channel has now been erased from the channel scan memory. The next time the CH +/- button is pressed, this channel will be skipped.

Repeat steps 1 and 2 to add or erase other channels.

### CAUTION

When a VHF or UHF channel is erased the cable TV channel with the same number is also erased, and vice versa.

Number on this TV	1	5	6	14	15	16	17	18	19	20	21	22	23	24	25	26	27	28	29	30		
Corresponding CATV channel	A-8	A-7	A-6	A	B	C	D	E	F	G	H	I	J	K	L	M	N	O	P	Q		
	31	32	33	34	35	36	37	38	39	93	94	95	96	97	98	99	100	101	102	123	124	125
	R	S	T	U	V	W	W+1	W+2	W+3	W+4	W+5	W+6	W+7	W+8	W+9	W+10	W+11	W+12	W+13	W+14	W+15	W+16

Check with your local cable TV company for more complete information on the available channels.

### Note

Pay cable TV systems use scrambled or encoded signals and require special converters (decoders) in addition to the normal cable connection.

### Cable TV channel chart\*

Cable TV systems use letters or numbers to designate channels. To tune in a channel, refer to the chart below.

\* This designation of cable TV channels conforms to the EIA/NCTA recommendation.

## 1.3. USING THE TIMER/BLOCK FUNCTIONS

### Available Functions

Internal clock	Once the internal clock is set, the current time will be displayed on the screen. You must set the clock correctly to activate the program start TIMER and channel BLOCK.
Program start TIMER	Makes a program of your choice appear on the screen automatically at the desired time.
Channel BLOCK	Blocks a channel from appearing on the screen for 12 hours. Use channel BLOCK to prevent children from watching undesirable programs.

The buttons used for the above functions are located on the Remote Commander.

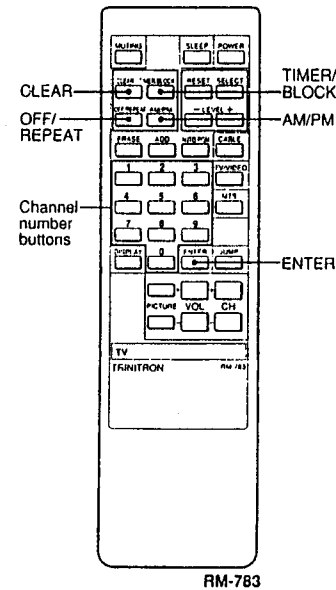

To set the internal clock, program start TIMER and channel BLOCK, you need to go into the corresponding "pages": "clock page," "TIMER page" and "BLOCK page."

To change the "pages," press TIMER/BLOCK.

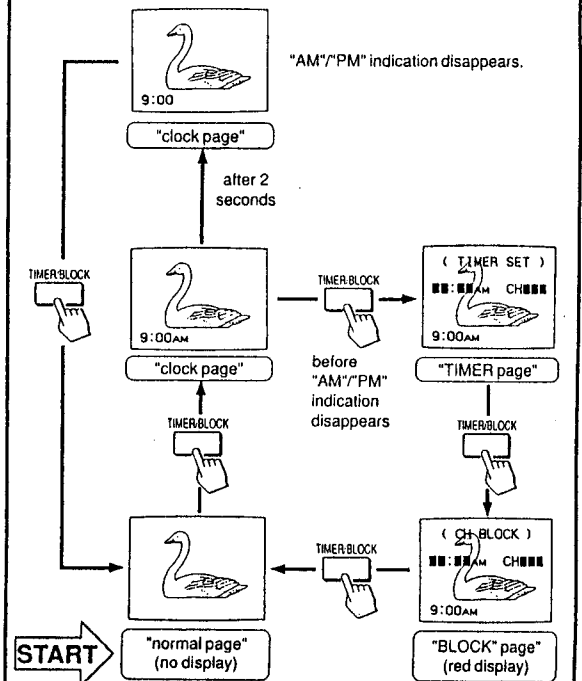

### CAUTION

- All settings will be erased from the TV's memory if the TV is unplugged, or if a power failure occurs.
- The TIMER and BLOCK functions will operate only if the clock is set correctly.
- If the TIMER and BLOCK are set for overlapping times on the same channel, the blocked channel will appear on the screen at the time set on the TIMER.

## Setting the Internal Clock

Example: To set the clock to 8:05 PM

- 1** From "normal page" (no display), press **TIMER/BLOCK** once to change to "clock page."

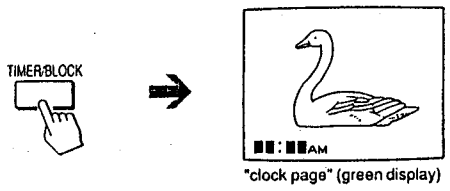

"clock page" (green display)
- 2** Press 0, 8, 0, 5, AM/PM. (You must press the 0's)

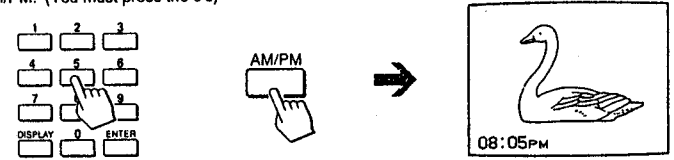

AM/PM
- 3** If you have performed the operation correctly, press **ENTER**. The screen display will blink once, indicating that the clock has been set. (The 0 in front will disappear.)

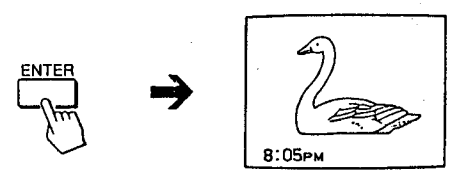

ENTER

If you make a mistake, press **CLEAR** and proceed from step 2. The "AM/PM" indication will disappear after a few seconds.

To summon "TIMER page," press **TIMER/BLOCK** before the "AM"/"PM" indication disappears.

To return to "normal page," press **TIMER/BLOCK** after the "AM"/"PM" indication has disappeared.

To reset the clock, summon "clock page" and press **CLEAR** before the "AM"/"PM" indication disappears. Then follow the steps above from step 2.

12:00 AM stands for midnight.  
12:00 PM stands for noon.

## Setting Channel BLOCK

Make sure that the clock has been set correctly before setting channel BLOCK. (p. 17)

EXAMPLE: To set a BLOCK for a program which begins at 9:30 AM on channel 8

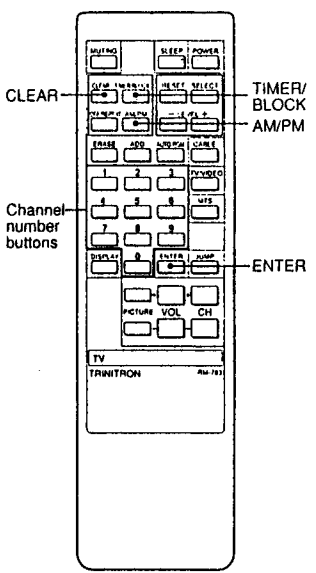

- 1** To change from "normal page" to "BLOCK page," press **TIMER/BLOCK** three times.

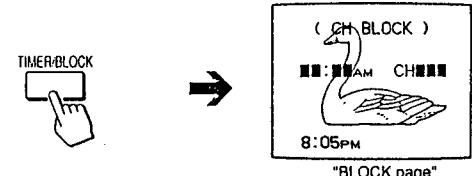

"BLOCK page"
- 2** Press 0, 9, 3, 0, **ENTER** (you must press the 0's). The screen display will blink once, indicating that the time has been set. Press 8, **ENTER** (0 not necessary). The numbers will blink, indicating that the channel has been set.

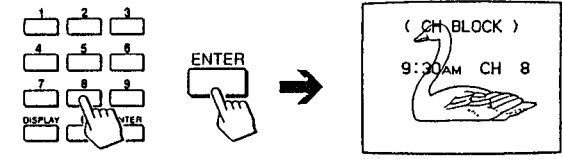

ENTER

The display **BLOCKED** will appear for a few seconds, then **(CH BLOCK)**. The Channel BLOCK has now been set.

If you make a mistake, press **CLEAR** and proceed from step 2.

At the preset time, the picture of the selected channel will be blocked from view and the sound will be muted. The display "BLOCKED" will appear for a few seconds, then **(CH BLOCK)** which will remain on the screen during the time the channel is blocked. (Both displays in red)

Normal reception will resume automatically after 12 hours.

To restore normal reception while the channel is blocked, recall "BLOCK page" and press **CLEAR**.

The BLOCK setting blocks a specified channel for the same 12-hour period every day.

To clear the BLOCK setting, summon "BLOCK page" and press **CLEAR**.

To reset, clear the setting and follow the steps above from step 2.

## Setting the Program Start TIMER

Make sure that the clock has been set correctly before setting the program start TIMER.

EXAMPLE: To set the TIMER for a program which begins at 10:30 PM on channel 12

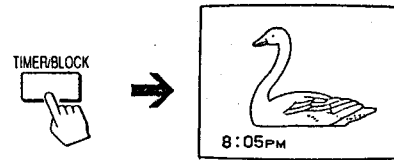
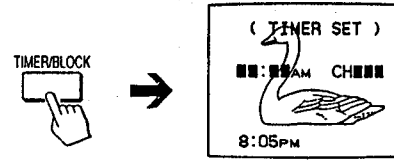
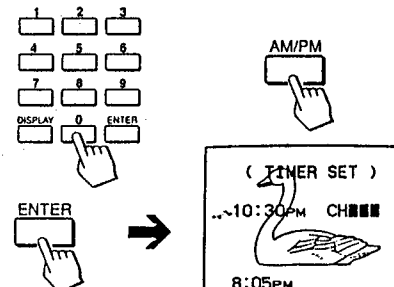
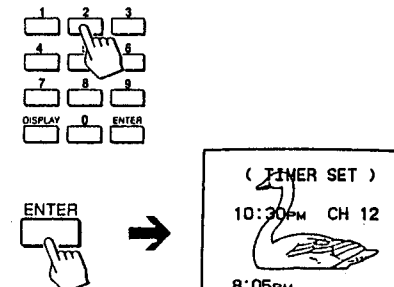
<p><b>1</b> From "NORMAL page," (no display) press <b>TIMER/BLOCK</b> once to change to "clock page."</p> 	<p><b>2</b> Press <b>TIMER/BLOCK</b> again before the "AM"/"PM" indication disappears to summon "TIMER page."</p> 
<p><b>3</b> Press 1, 0, 3, 0, AM/PM, ENTER. The screen display will blink once, indicating that the time has been set.</p>  <p>The TIMER lamp will light up, indicating that the TIMER has been set.</p>	<p><b>4</b> Press 1, 2, ENTER (0 not necessary). The screen display will blink once, indicating that the channel has been set.</p> 

If you make a mistake, press CLEAR and proceed from step 3.

At the preset time, the selected channel will appear on the screen and the TIMER lamp will go out. The TIMER will operate whether you are watching a TV program or a VCR playback, or even if the TV is turned off.

If no button is pressed within 2 hours after the preset time, an "OFF" display will appear on the screen for 1 minute. If a button is still not touched during that minute, the TV will turn off automatically as a safety precaution.

The TIMER operates only once, but the time and the channel will remain in the TV's memory.

To preset the same channel at the same time for a future date, press OFF/REPEAT. The TIMER lamp will light up, indicating that the TIMER has been reactivated.

To deactivate the TIMER, press OFF/REPEAT again so that the TIMER lamp goes out. It is not necessary to summon "TIMER page" before using the OFF/REPEAT button. Furthermore, this button is effective even if the TV is turned off.

To clear the TIMER setting, summon "TIMER page" and press CLEAR.

To reset, clear the setting and follow the steps from step 3.

## 1-4. OTHER USEFUL FEATURES

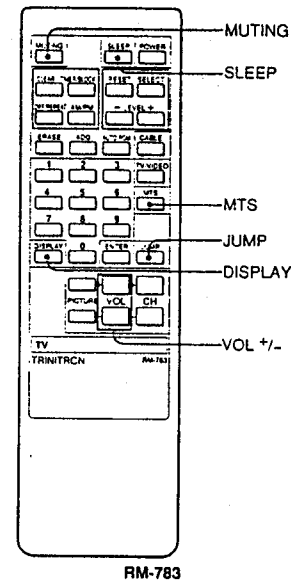

### Muting the sound – MUTING button

1. Press **MUTING**.
2. The display "MUTING" will appear on the screen.
3. To restore the sound, press **MUTING** again, or press **VOL +**.

### Using the SLEEP timer – SLEEP button

TO SET: (Turns TV off automatically about 1 hour after setting)

1. Press **SLEEP**.
2. A green "SLEEP ON" display appears for a few seconds.
3. A red "SLEEP" display will appear 1 minute before the TV shuts off.

TO CANCEL:

Press **SLEEP** again.

A green "SLEEP OFF" display appears for a few seconds.

OR

Turn the TV off. The sleep timer setting will be cancelled.

### Receiving a Multichannel TV Sound Program – MTS button (KV-20TS27, KV-2137RS only)

Each time you press **MTS**, the **MAIN**, **SAP** (Second Audio Program) and **MONO** modes are selected in sequence. The display (in green) for each mode will appear on the screen for a few seconds.

(NOTE: During SAP mode, the sound of non-SAP programs will be muted.)

TO LISTEN TO STEREO SOUND:

1. Press **MTS** to select the **MAIN** mode.
2. The **MAIN** display will appear on screen.
3. The **STEREO** indicator lamp on the TV will light up whenever a stereo broadcast is received.

NOTE: A weak incoming signal may cause excessive noise with some stereo broadcasts.

Switch to **MONO** mode to eliminate this noise.

### Switching quickly between 2 channels – JUMP button



Each time you press the **JUMP** button, the channel which appeared on the screen immediately before is recalled. Use this feature to keep track of two programs alternately.

### Keeping the channel displayed – DISPLAY button



TO **DISPLAY** the channel:  
Press **DISPLAY**.  
The channel display will remain on the screen.

TO **CANCEL** the display:  
Press **DISPLAY** again.  
The channel display will disappear.

## SECTION 2 DISASSEMBLY

### 2-1. REAR COVER REMOVAL

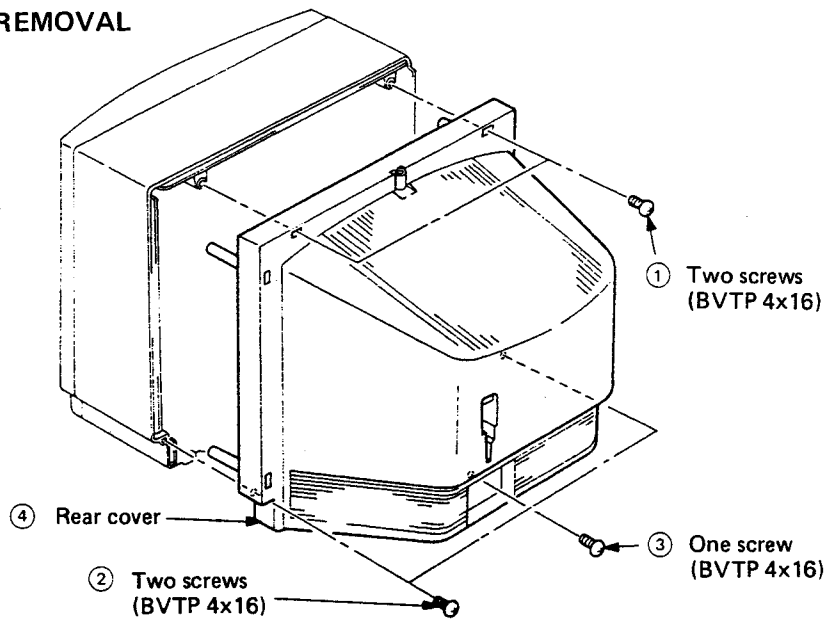

### 2-2. PICTURE TUBE REMOVAL

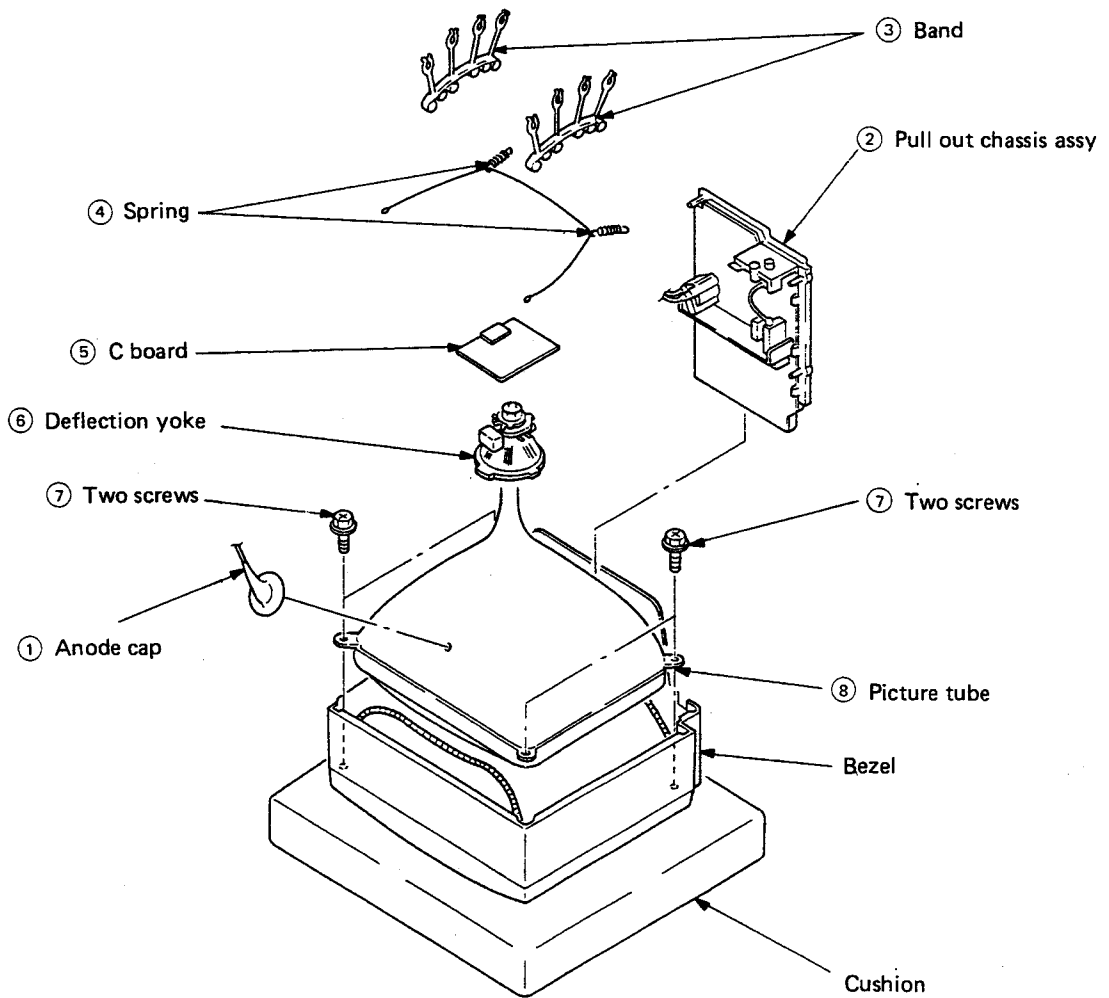

**2-3. SERVICE POSITION**

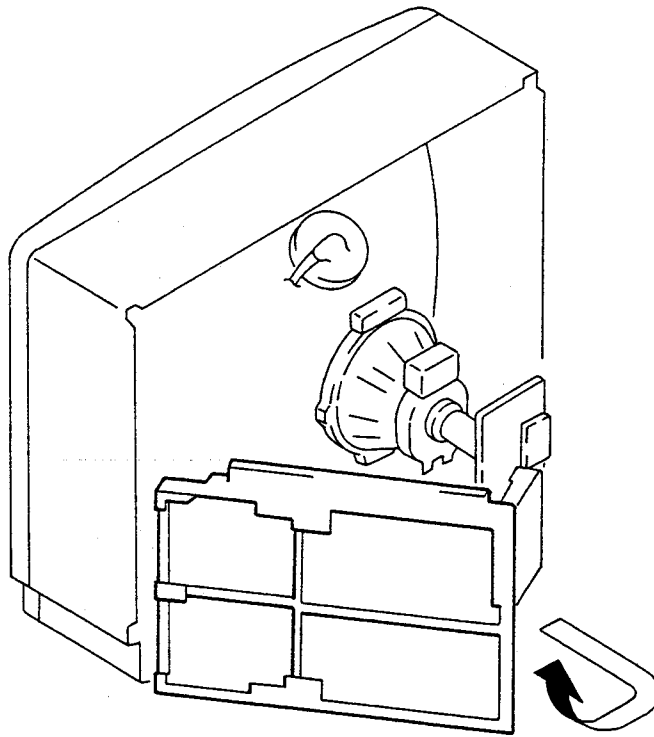

**• REMOVAL OF ANODE-CAP  
- REMOVING PROCEDURES**



① Turn up one side of the rubber cap in the direction indicated by the arrow ②.

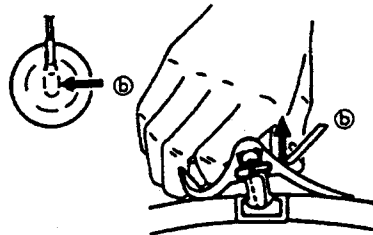

② Using a thumb pull up the rubber cap firmly in the direction indicated by the arrow ①.

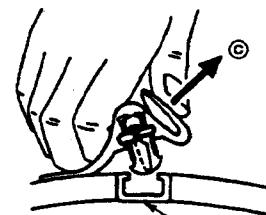

Anode button

③ When one side of the rubber cap is separated from the anode button, the snode-cap can be removed by turning up the rubber cap and pulling up it in the direction of the arrow ③.

**• HOW TO HANDLE AN ANODE-CAP**

- ① Don't hurt the surface of anode-caps with sharp shaped material!
- ② Don't press the rubber hardly not to hurt inside of anode-caps!  
A material fitting called as shatter-hook terminal is built in the rubber.
- ③ Don't turn the foot of rubber over hardly!  
The shatter-hook terminal will stick out or hurt the rubber.

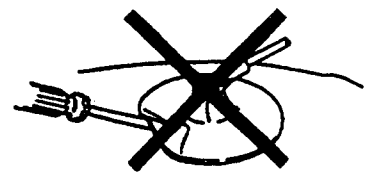
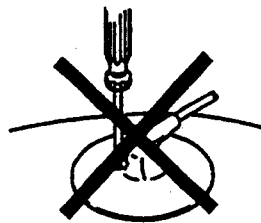

## SECITON 3 SET-UP ADJUSTMENTS

- The following adjustments should be made when a complete realignment is required or a new picture tube is installed.
- These adjustments should be performed with rated power supply voltage unless otherwise noted.

Controls and switch should be set as follows unless otherwise noted :

PICTURE control ..... MAXIMUM  
BRIGHTNESS control ..... MAXIMUM

Perform the adjustments in order as follows :

1. Beam Landing
2. Convergence
3. Focus
4. Sub Brightness
5. White Balance

**Note :** Test Equipment Required.

1. Color-bar/Pattern Generator
2. Degausser

### 3-1. BEAM LANDING

**Preparation.**

- Feed in the white pattern.
  - Before starting, degauss the entire screen.
1. Loosen deflection yoke screw.
  2. Adjust purity control as shown in Fig.3-1.
  3. Slide deflection yoke as far forward as it will go.
  4. Turn the raster signal of the pattern generator to red.
  5. Adjust purity control to center vertical red band as shown in Fig.3-2.
  6. Slide deflection yoke back for a uniform red screen.
  7. Check green and blue rasters for uniformity by performing the same way as steps 4, 5 and 6.
  8. Tighten the deflection yoke screw.
  9. Check if mislanding appears at corners a—d as shown in Fig. 3-3. If mislanding is observed, correct it as shown in Fig. 3-3.
  10. Confirm that beam landing is correct when the receiver is faced in all directions.

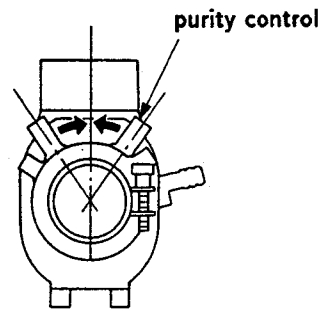

Fig. 3-1.

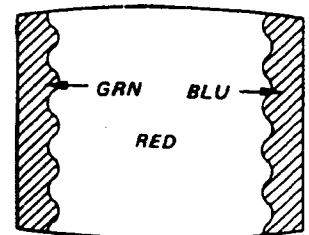

Fig. 3-2.

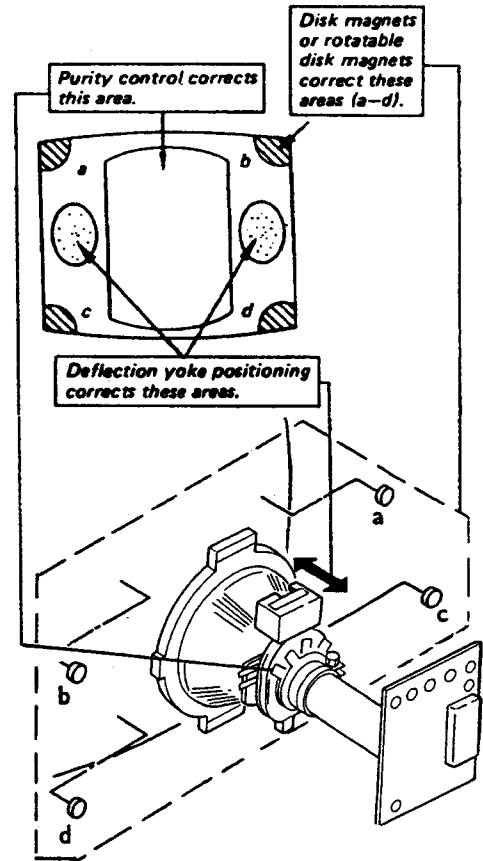
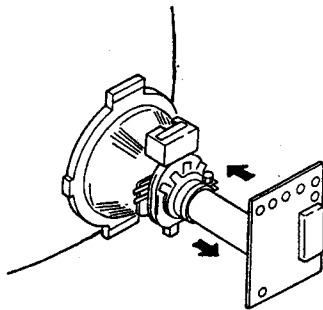

Fig. 3-3.

### 3-2. CONVERGENCE

**Preparation :**

- Before starting, perform FOCUS, H. SIZE and V. SIZE adjustments.
- Set BRIGHTNESS control to fully counterclockwise.
- Feed in the dot pattern.

**(1) Horizontal and Vertical Static Convergence**

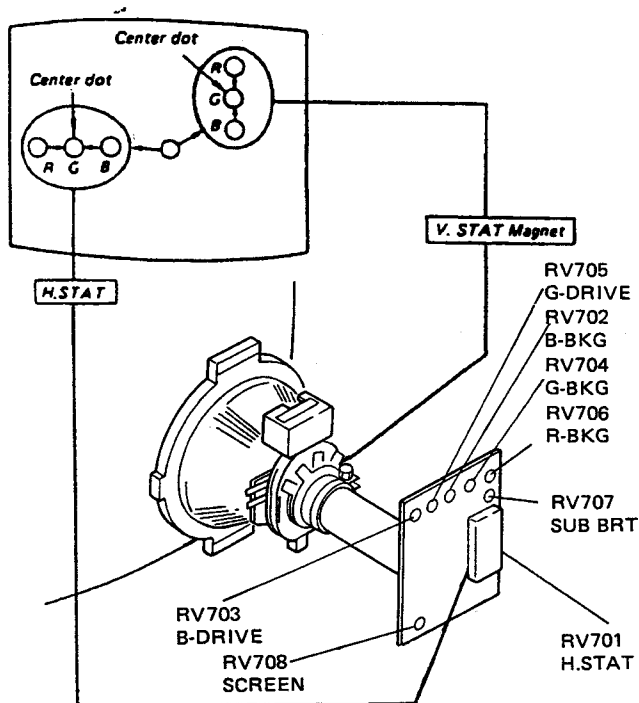

1. Adjust H. STAT VR to coincide red, green and blue dots on the center of screen.  
(Horizontal movement)
  2. Adjust V. STAT magnet to coincide red, green and blue dots on the center of screen.  
(Vertical movement)
  3. If the red, green and blue dots do not coincide on the center of screen with H. STAT VR, perform horizontal convergence adjustment using H. STAT VR and V. STAT magnet as shown below.  
(In this case, H. STAT VR and V. STAT magnet effect each other.)
- Tilt the V. STAT magnet and adjust static convergence to open or close the V. STAT magnet.

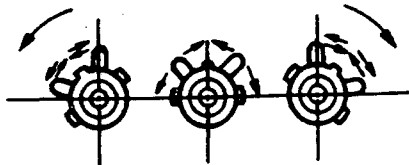

4. When the V. STAT magnet is moved in the direction of arrow (a) and (b), Red, Green and Blue dots move as shown below.

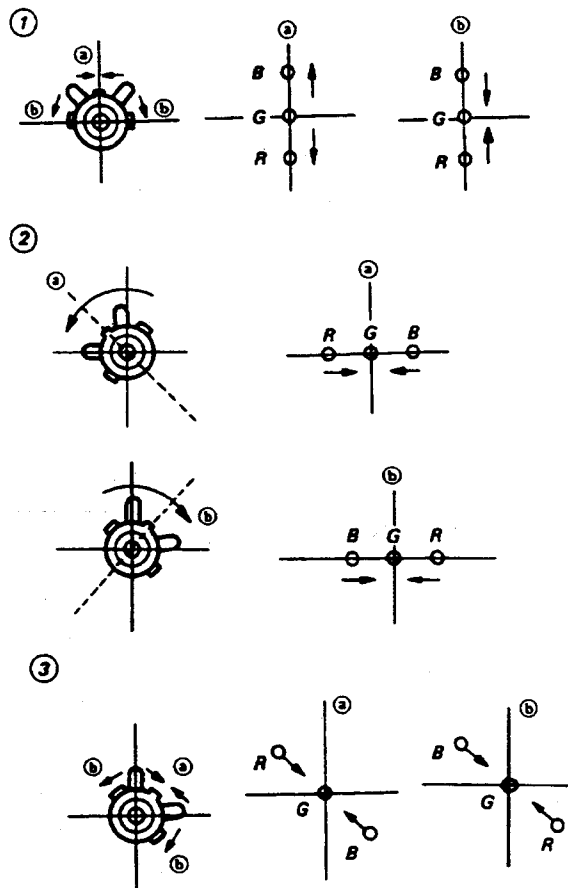

If blue dot dose not coincide with red and green dots, perform following steps.

Move BMC magnet (a) to correct insufficient H. static convergence.

Rotate BMC magnet (b) to correct insufficient V. static convergence.

In either case, repeat Beam Landing Adjustment.

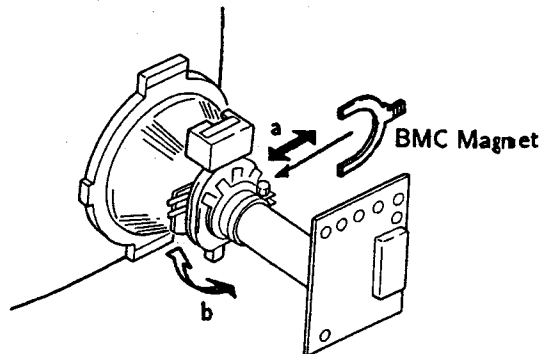



**(2) Dynamic Convergence Adjustment**

**Preparation :**

- Before starting, perform Horizontal and Vertical Static Convergence Adjustment.
- 1. Loosen deflection yoke screw.
- 2. Remove deflection yoke spacers.
- 3. Move the deflection yoke for best convergence as shown below.
- 4. Tighten the deflection yoke screw.
- 5. Install the deflection yoke spacers.

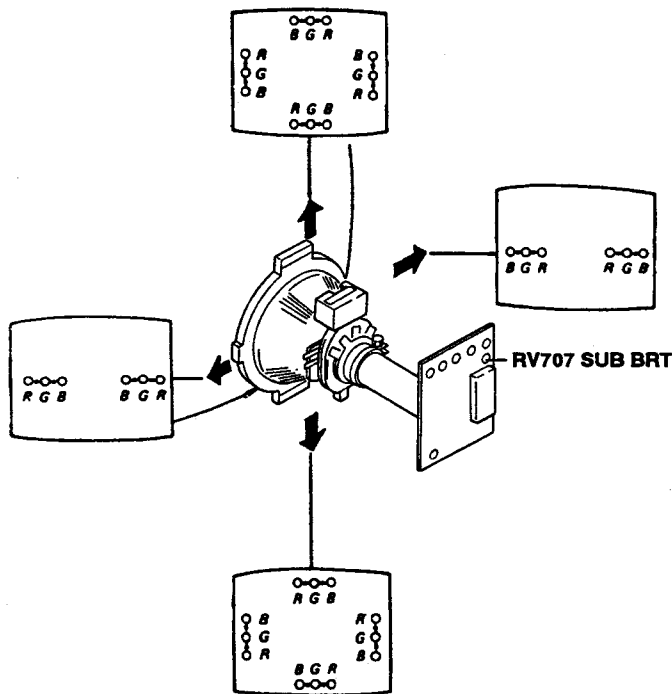

**(3) Screen-corner Convergence**

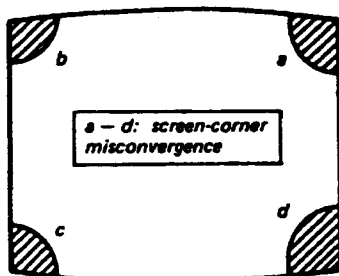

**3-3. FOCUS (G4)**

Adjust FOCUS control for a best picture.

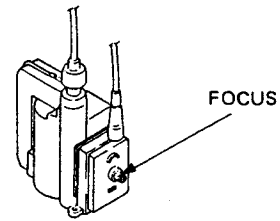

**3-4. SUB BRT (RV707)**

1. Feed in a cross-hatch pattern.
2. Set PICTURE and BRIGHTNESS to minimum.
3. Turn RV707 (SUB BRT) slowly to obtain a faintly visible cross-hatch.

**3-5. WHITE BALANCE**

Feed in the cross-hatch pattern.

1. Set BRIGHTNESS and PICTURE controls to minimum.
2. Turn RV703 (B.DRIVE) and RV705 (G. DRIVE) fully counterclockwise.
3. Set RV706 (R.BKG), RV704 (G.BKG), RV702 (B.BKG) and RV707 (SUB BRT) to mechanical center.
4. Turn RV708 (SCREEN) slowly to obtain a faintly visible cross-hatch. Note the color that first becomes visible by turning RV708. Do not turn a BKG control for this color.
5. Adjust the other two BKG controls for best white balance (neutral gray) of the faint cross-hatch.
6. Set BRIGHTNESS and PICTURE controls to maximum. Observe the screen and adjust the DRIVE controls for best white balance.
7. Repeat Steps 1 through 6 several times.

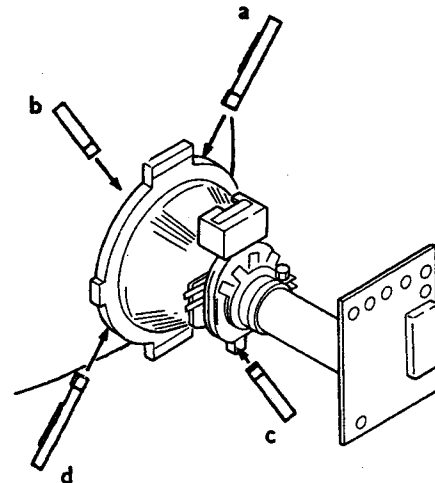

Permalloy

## SECTION 4 SAFETY RELATED ADJUSTMENTS

### ☒ R324 CONFIRMATION METHOD (HV HOLD-DOWN CONFIRMATION) AND READJUSTMENTS

The following adjustments should always be performed when replacing the following components (marked with ☒ on the schematic diagram).  
IC601, IC301, PM501, D501, D321, C565, C563, R565, R512, R325, R324, T504, DY

#### 1. Preparation before confirmation

- 1) Turn the POWER switch ON, and receive entirely white signals and set the PICTURE and BRIGHT controls to maximum.
- 2) Confirm that voltage of the check terminal of pin ④ of A-14 (A BOARD) is more than 110.0V DC when the set is operating normally with 120.0±2.0V AC supply.

#### 2. Hold-down operation confirmation

- 1) Turn the POWER switch ON, and receive entirely white signals and adjust ABL current to  $1430 \pm 50 \mu\text{A}$  with PICTURE and BRIGHT etc controls.
- 2) Apply DC voltage to the check terminal of pin ④ of A-14 (A BOARD) via 1T40 from the DC stabilized power source.

Confirm that the minimum voltage is less than 129.0V DC whereby the raster disappears during operation of hold-down circuit.

**NOTE:** When the hold-down circuit starts operating, switch OFF the POWER of the set immediately.

- 3) Turn the POWER switch ON, and receive dot signals and adjust ABL current to  $140 \pm 50 \mu\text{A}$  with PICTURE and BRIGHT etc controls.
- 4) Apply DC voltage to the check terminal of pin ④ of A-14 (A BOARD) via 1T40 from the DC stabilized power source.

Confirm that the minimum voltage is less than 129.0V DC whereby the raster disappears during operation of hold-down circuit.

**NOTE:** When the hold-down circuit starts operating, switch OFF the POWER of the set immediately.

#### 3. Hold-down readjustment

When step 2 is not satisfied, readjustment should be performed by altering the resistance value of R324 (a component marked with ☒).

### ☒ R322 CONFIRMATION METHOD (+B HOLD-DOWN CONFIRMATION) AND READJUSTMENTS

The following adjustments should always be performed when replacing the following components (marked with ☒ on the schematic diagram).  
IC301, PM501, D501, R565, R512, R322

#### 1. Preparation before confirmation

- 1) Supply  $120 \pm 2.0\text{V}$  AC to with variable auto-transformer.

#### 2. Hold-down operation confirmation

- 1) Turn the POWER switch ON, and receive entirely white signals and adjust ABL current to  $1430 \pm 50 \mu\text{A}$  with PICTURE and BRIGHT etc controls.
- 2) Apply DC voltage to the check terminal of pin ② of PM501 (A BOARD) via 1T40 from the DC stabilized power source. Confirm that the minimum voltage is less than 155.5V DC whereby the raster disappears during operation of hold-down circuit.

**NOTE:** When the hold-down circuit starts operating, switch OFF the POWER of the set immediately.

- 3) Turn the POWER switch ON, and receive dot signals and adjust ABL current to  $140 \pm 50 \mu\text{A}$  with PICTURE and BRIGHT etc controls.

- 4) Apply DC voltage to the check terminal of pin ② of PM501 (A BOARD) via 1T40 from the DC stabilized power source. Confirm that the minimum voltage is less than 155.5V DC whereby the raster disappears during operation of hold-down circuit.

**NOTE:** When the hold-down circuit starts operating, switch OFF the POWER of the set immediately.

#### 3. Hold-down readjustment

When step 2 is not satisfied, readjustment should be performed by altering the resistance value of R322 (a component marked with ☒).

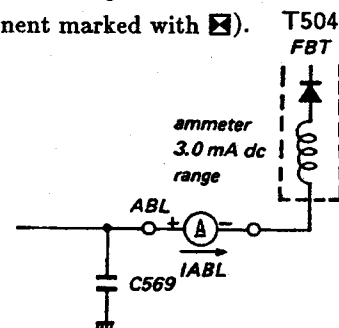

\*Use a digital multimeter whose input impedance is over  $100\text{M}\Omega$  when confirming the voltage of the protector terminal.

SECTION 5  
CIRCUIT ADJUSTMENTS

**+B VOLTAGE CONFIRMATION**

The following adjustments should always be performed when replacing IC601.

- 1) Supply  $130 \pm 2.0$  V AC to with variable auto-transformer.
- 2) Receive entirely monoscope signal.
- 3) Set the PICTURE control and the BRIGHT controls in to initial reset.
- 4) Confirm the voltage of pin ① of A-14 ( A BOARD) is less than 138.0V DC.
- 5) If step 4) is not satisfied, replace IC601 repeat above steps.

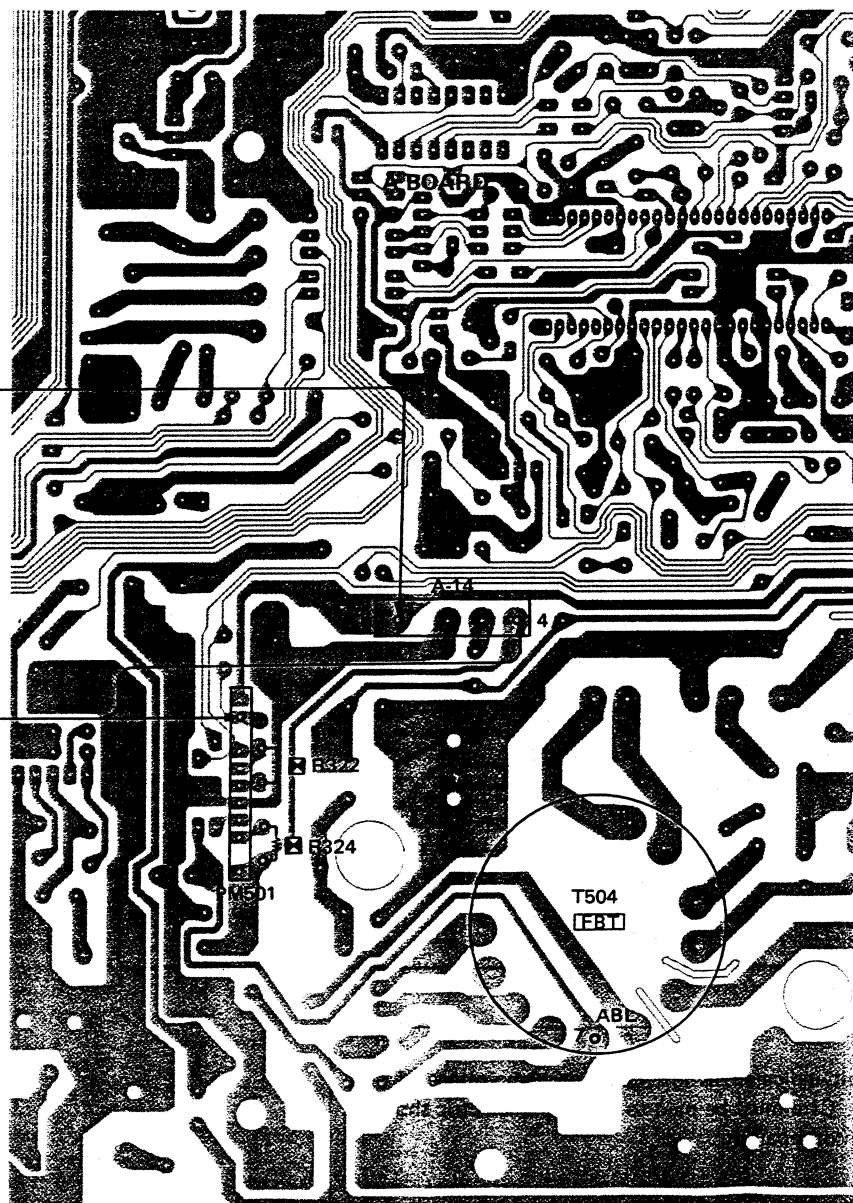
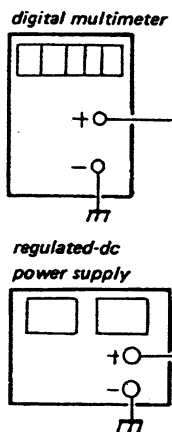
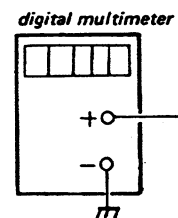

5-1. A BOARD ADJUSTMENTS

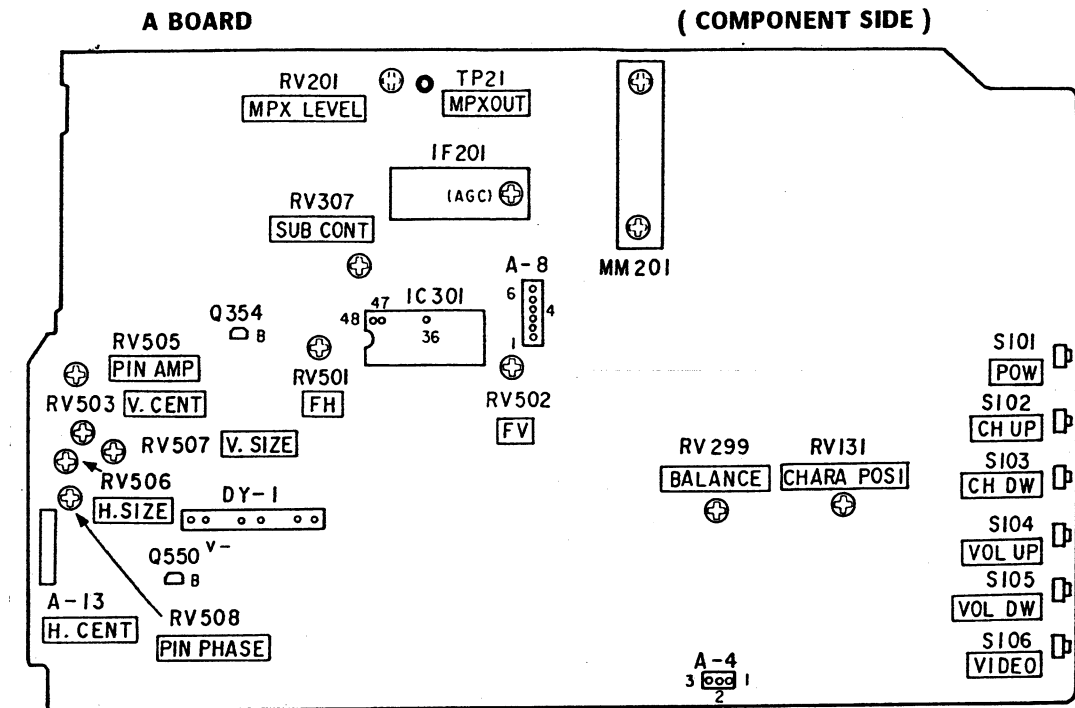

**CHARA POSITION ADJUSTMENT (RV131)**

1. Receive a color-bar signal.
2. Set the PICTURE button to maximum.
3. Adjust RV131 to the point where the arrow indicate.

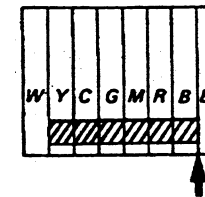

**RF AGC ADJUSTMENT (IF201)**

1. Receive an off-air signal.
2. Adjust AGC VR (AGC VR of IF201) so that snow noise and cross-modulation just disappear from the picture.

**MPX LEVEL ADJUSTMENT (RV201)**

1. Receive 400Hz (100% modulation) sound signal.
2. Connect an oscilloscope to TP21 (MPX OUT).
3. Adjust RV201 so that the MPX level is  $0.7 \pm 0.03$  Vp-p.

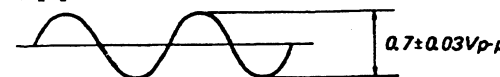

**(KV-20TS27 ONLY)**

**AUDIO BALANCE ADJUSTMENT (RV299)**

1. Receive monoral signal.
2. Connect the dual-trace-oscilloscope at SP out Lch (A-4 connector ①) and Rch (A-4 connector ②).
3. Adjust RV299 so that Lch and Rch are same level.

**SUB CONTRAST ADJUSTMENT (RV307)**

1. Receive a color-bar signal.  
PICTURE ..... MAX  
BRT ..... CENTER  
COLOR ..... MIN
2. Connect circuit between Base of Q354 and 9.0V line with a jumper wire.
3. Draw A-8 - C-3 connector (C Board).
4. Connect an oscilloscope to the pin ④ of A-8 connector (blue out).
5. Adjust RV307 (SUB CONT) so that voltage is  $2.1 \pm 0.05$  Vp-p.

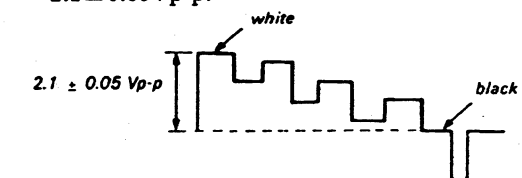

H.FI

1.  
2.  
3.  
4.  
5.

V.FI

1.  
2.  
3.  
4.  
5.

PIN

Adj

PIN

Adj

H.C

1.  
2.  
3.

V.C

1.  
2.  
3.

## SECTION 5 CIRCUIT ADJUSTMENTS

### 5-1. A BOARD ADJUSTMENTS

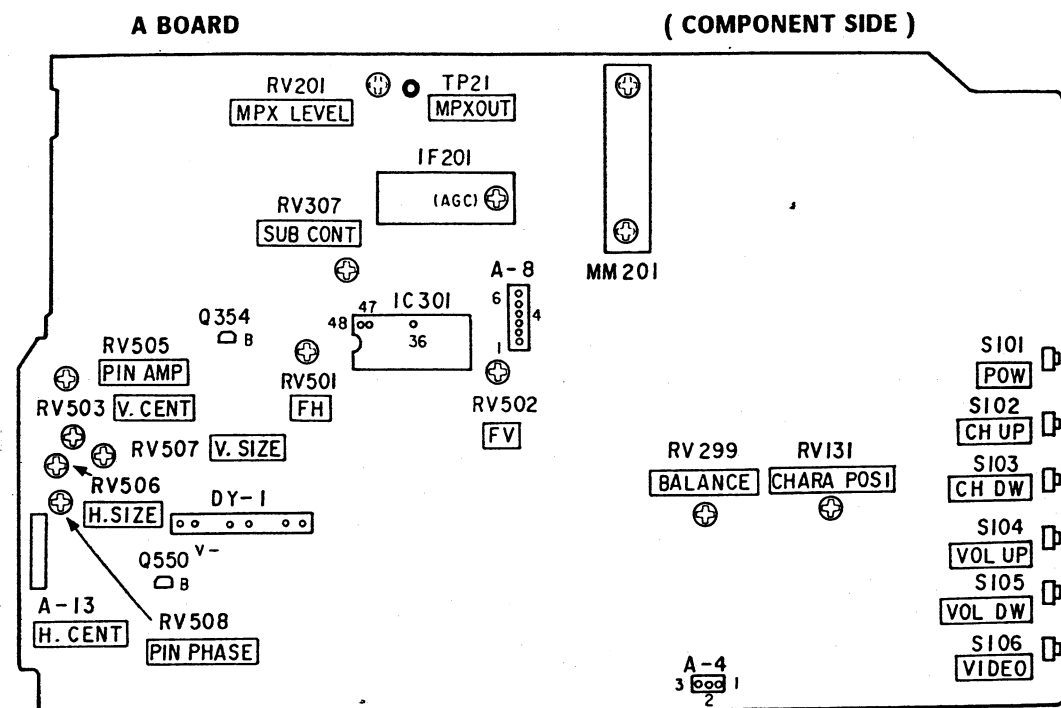

#### CHARA POSITION ADJUSTMENT (RV131)

1. Receive a color-bar signal.
2. Set the PICTURE button to maximum.
3. Adjust RV131 to the point where the arrow indicate.

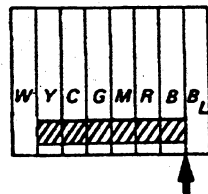

#### RF AGC ADJUSTMENT (IF201)

1. Receive an off-air signal.
2. Adjust AGC VR (AGC VR of IF201) so that snow noise and cross-modulation just disappear from the picture.

#### MPX LEVEL ADJUSTMENT (RV201)

1. Receive 400Hz (100% modulation) sound signal.
2. Connect an oscilloscope to TP21 (MPX OUT).
3. Adjust RV201 so that the MPX level is  $0.7 \pm 0.03$  Vp-p.

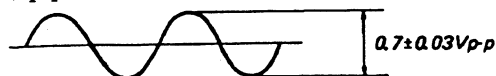

#### (KV-20TS27 ONLY)

#### AUDIO BALANCE ADJUSTMENT (RV299)

1. Receive monoral signal.
2. Connect the dual-trace-oscilloscope at SP out Lch (A-4 connector ①) and Rch (A-4 connector ②).
3. Adjust RV299 so that Lch and Rch are same level.

#### SUB CONTRAST ADJUSTMENT (RV307)

1. Receive a color-bar signal.  
PICTURE ..... MAX  
BRT ..... CENTER  
COLOR ..... MIN
2. Connect circuit between Base of Q354 and 9.0V line with a jumper wire.
3. Draw A-8 - C-3 connector (C Board).
4. Connect an oscilloscope to the pin ④ of A-8 connector (blue out).
5. Adjust RV307 (SUB CONT) so that voltage is  $2.1 \pm 0.05$  Vp-p.

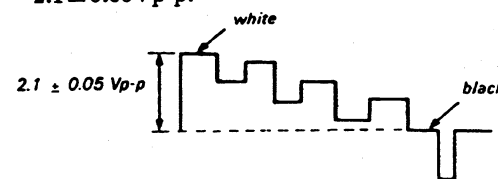

#### H.FREQ ADJUSTMENT (RV501)

1. Receive an off-air signal.
2. Connect circuit between pin ④ of IC301 (H IN) and pin ⑤ of IC301 (VCC2) with a jumper wire.
3. Connect the frequency counter across Base of Q550 and ground.
4. Adjust RV501 for  $15,734\text{kHz} \pm 70\text{Hz}$  on the frequency counter.
5. Disconnect a jumper wire from IC301.

#### V.FREQ ADJUSTMENT (RV502)

1. Receive an off-air signal.
2. Connect circuit between pin ④ of IC301 (V IN) and pin ⑤ of IC301 (VCC2) with a jumper wire.
3. Connect the frequency counter across DY-1 connector (V.DY ⊖) and ground.
4. Adjust RV502 for  $55.0 \pm 0.3\text{Hz}$  on the frequency counter.
5. Disconnect a jumper wire from IC301.

DY-1 connector

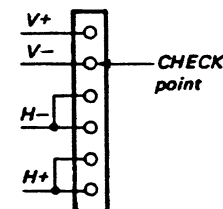

#### H.SIZE ADJUSTMENT (RV506)

1. Receive a monoscope signal.
2. Adjust RV506 for  $15.0 \pm 0.2$  divisions.

#### V.SIZE ADJUSTMENT (RV507)

1. Receive a monoscope signal.
2. Adjust RV507 for  $11.25 \pm 0.1$  divisions.

#### PIN AMP ADJUSTMENT (RV505)

Adjust pin amplification with RV505.



#### PIN PHASE ADJUSTMENT (RV508)

Adjust pin phase with RV508.

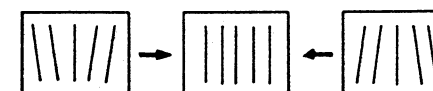

#### H.CENT ADJUSTMENT (A-13)

1. Receive a cross-hatch signal.
2. Set PICTURE and BRT to normal.
3. Adjust H.CENT (H.CENT TAP=A-13) for best picture.

#### V.CENT ADJUSTMENT (RV503)

1. Receive a cross-hatch signal.
2. Set PICTURE and BRT to normal.
3. Adjust V.CENT (RV503) for best picture.

### WARNING !!

When you replace a memory IC, make sure of the functioning remote commander and proper sound with the power switch on.

If you find any troubles, take actions as shown below.

For remote commander :

Set the main power switch to OFF and press it again to turn the unit on.

For sound :

Switch the unit from MAIN to SAP to MONO mode by the MTS switch ( or MTS button on the commander ) to make sure of sound with MONO mode. Note that the sound is of proper volume and the speaker on/off switch is set to ON.

SECTION 6  
DIAGRAMS

6-1. CIRCUIT BOARDS LOCATION

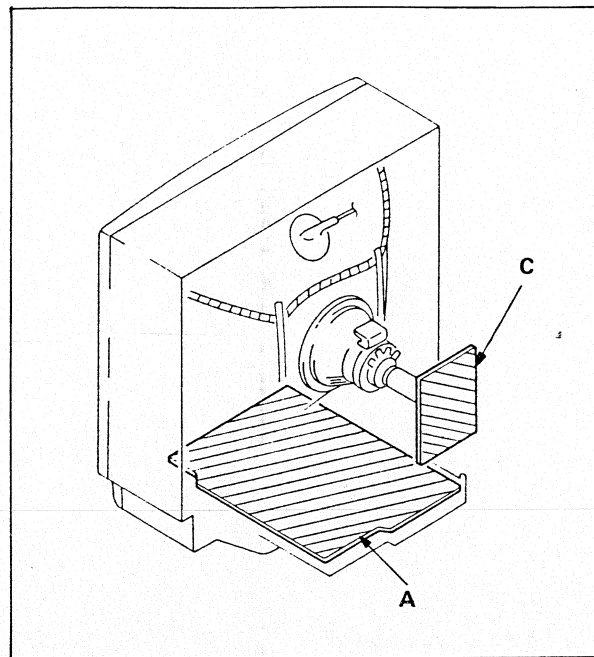

6-2. PRINTED WIRING BOARDS AND SCHEMATIC DIAGRAMS  
— Conductor Side —

Note: The components identified by shading and mark  $\Delta$  are critical for safety. Replace only with part number specified.

Note: Les composants identifiés par un tramé et une marque  $\Delta$  sont critiques pour la sécurité. Ne les remplacer que par une pièce portant le numéro spécifié.

Note:

- All capacitors are in  $\mu F$  unless otherwise noted. p:  $\mu \mu F$
- 50 WV or less are not indicated except for electrolytic and tantalums.
- All resistors are in ohms.
- $k\Omega = 1000\Omega$ ,  $M\Omega = 1000K\Omega$
- Indication of resistance, which does not have one for rating electrical power is as follows.

Pitch: 5 mm  
Rating electrical power: 1/4W

- : nonflammable resistor.
- : fusible resistor.
- $\Delta$  : internal component.
- $\square$  : panel designation or adjustment for repair.
- All variable and adjustable resistors have characteristic curve B, unless otherwise noted.

- The components identified by  $\square$  in this manual have been carefully factory-selected for each set in order to satisfy regulations regarding X-ray radiation. Should replacement be required, replace only with the value originally used.
  - When replacing components indicated by  $\square$  mark the necessary adjustments indicated. If results do not meet the specified value, change the component identified by  $\square$  and repeat the adjustment until the specified value is achieved. (Refer to R322, 324 adjustment on page 15)
- When replacing the part in below table, be sure to perform the related adjustment.

Part replaced ( $\square$ )	Adjustment ( $\square$ )
IC301, PM501, D501, R565, R512, R322	R322
IC601, IC301, PM501, D501, D321, C565, C563, R565, R512, R325, R324, T504, DY	R324

Reference information

- RESISTOR RN : METAL FILM  
RC : SOLID  
FPRD : NONFLAMMABLE CARBON  
FUSE : NONFLAMMABLE FUSIBLE  
RS : NONFLAMMABLE METAL OXIDE  
RB : NONFLAMMABLE CEMENT  
RW : NONFLAMMABLE WIREWOUND  
\* : ADJUSTMENT RESISTOR
- COIL LF-8L : MICRO INDUCTOR
- CAPACITOR TA : TANTALUM  
PS : STYROL  
PP : POLYPROPYLENE  
PT : MYLAR  
MPS : METALIZED POLYESTER  
MPP : METALIZED POLYPROPYLENE  
ALB : BIPOLAR  
ALT : HIGH TEMPERATURE  
ALR : HIGH RIPPLE

- Readings are taken with a color-bar signal input. MODE(AUDIO)
  - No mark : MAIN
  - ( ) : SAP
  - < > : MONO
- Readings are taken with a 10 M $\Omega$  digital multimeter.
- Voltage are dc with respect to ground unless otherwise noted.
- Voltage variations may be neted due to normal production tolerances.
- All voltages are in V.
- Circled numbers are wavestorm references.
- $\square$  B = bus
- $\square$  signal path

A

(TUNER VIF, SIF, CHROMA, AF OUT, Y AMP, CUSTOMER CONTROL, REMOTE CONTROL, TUNING CONTROL, H.DEF, V.DEF)

— A Board —

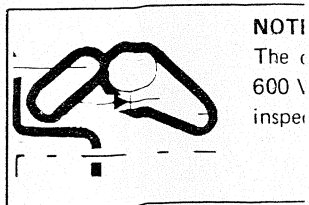
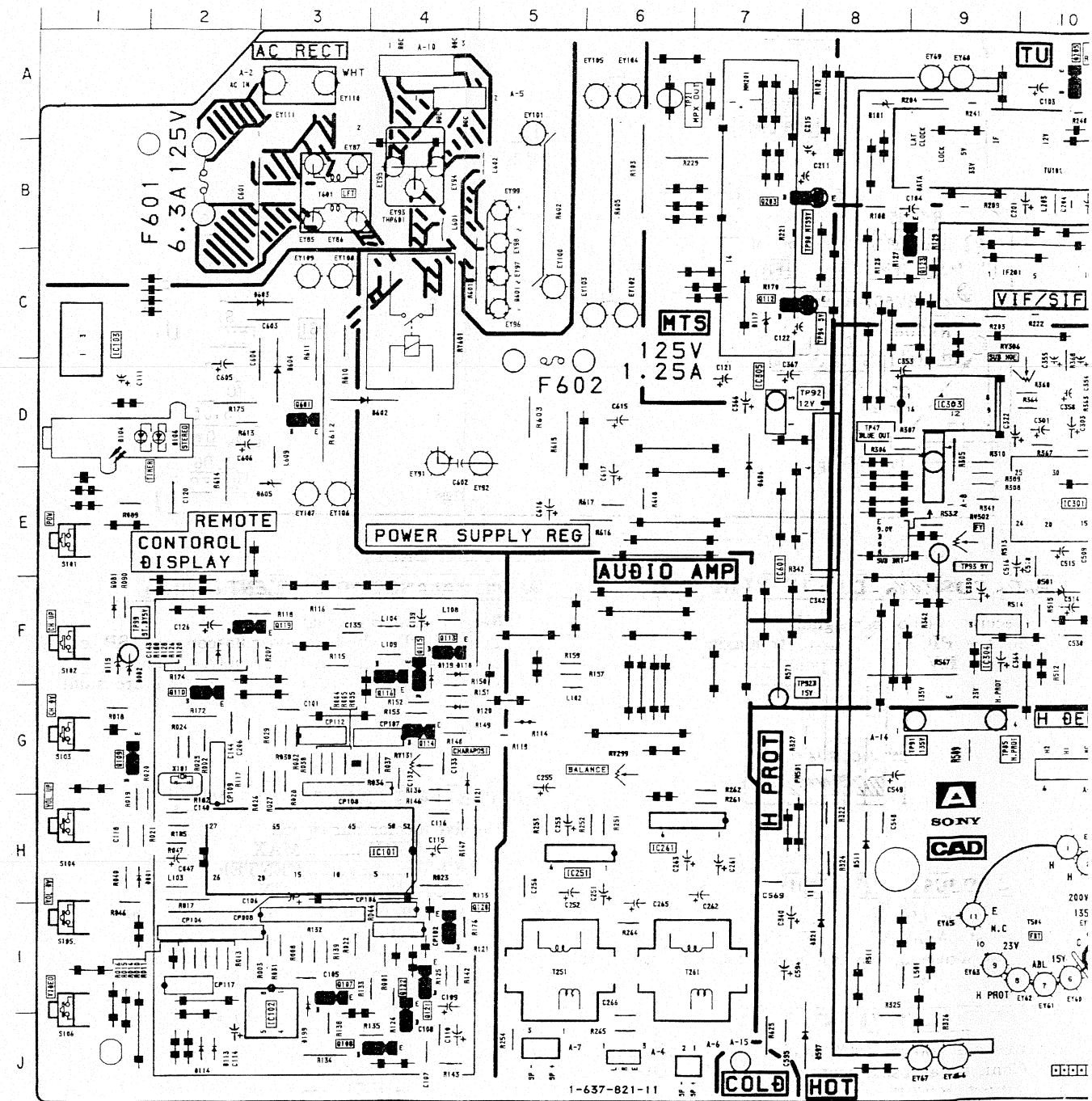

NOTE: The capacitor value is 600 V inspection.



**A** (TUNER VIF, SIF, CHROMA, AF OUT, Y AMP, CUSTOMER CONTROL, REMOTE CONTROL, TUNING CONTROL, H.DEF, V.DEF, POWER SUPPLY)

□ in this manual have been checked set in order to satisfy operation. Should replacement be made, use the original value. □ mark the component identified by □ and the specified value is achieved. (page 15) table, be sure to perform the

Adjustment (□)
R322
R324

- LM
- IMBLE CARBON
- IMBLE FUSIBLE
- IMBLE METAL OXIDE
- IMBLE CEMENT
- IMBLE WIREWOUND
- IENT RESISTOR
- DUCTOR
- M
- YPLENE
- ED POLYESTER
- ED POLYPROPYLENE
- IPERATURE
- PLE
- signal input.

igital multimeter,  
d unless otherwise noted,  
due to normal production

ances

— A Board —

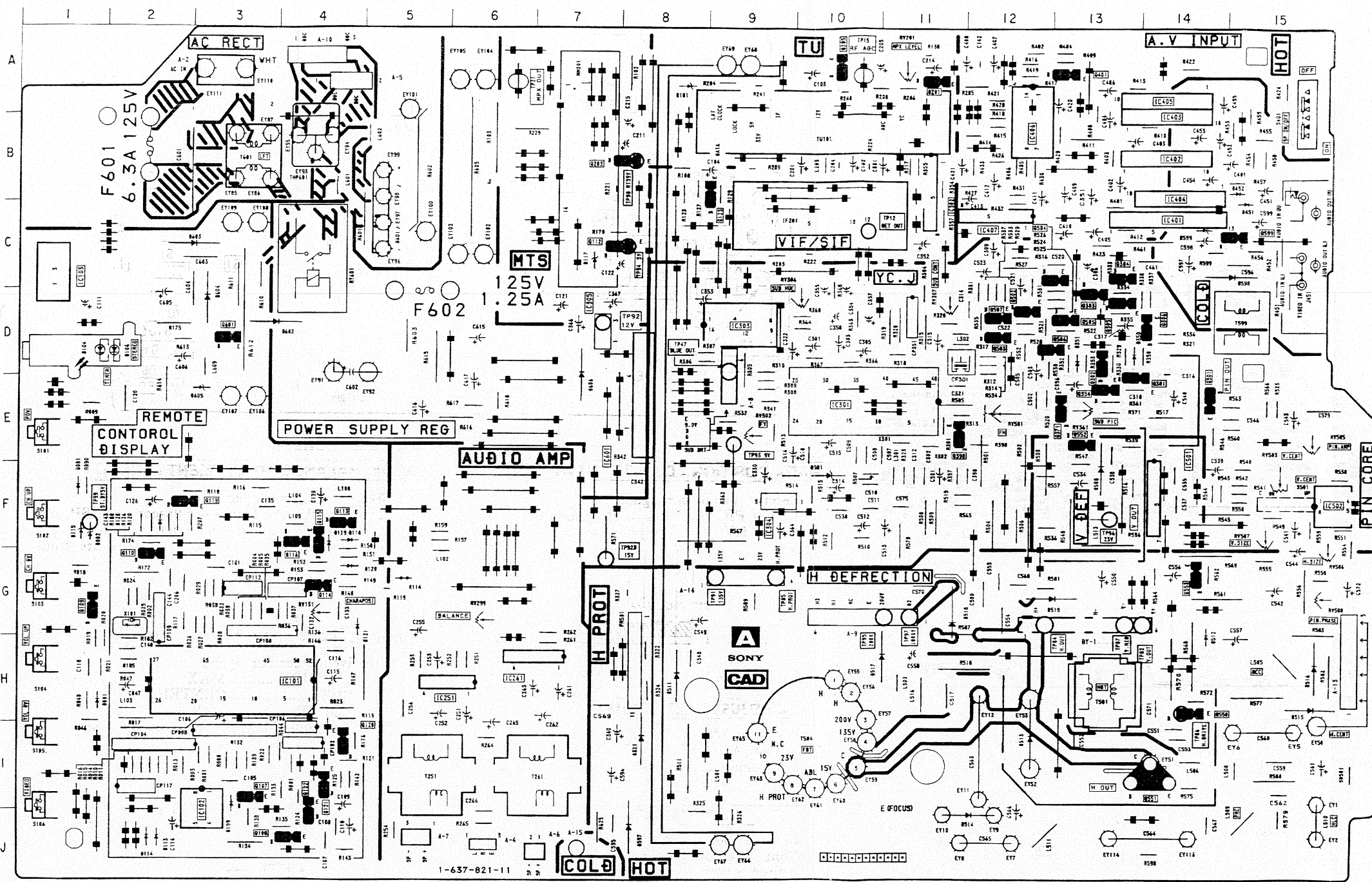

A BOARD LOCATION

IC	Q501	E-14	0603	C-3	
IC101	H-3	Q502	0-12	0604	0-3
IC102	J-3	Q503	0-12	0605	E-3
IC103	C-1	Q504	C-13	0606	E-7
IC251	H-6	Q505	0-13		
IC261	H-7	Q506	0-13		
IC301	E-10	Q507	0-12		
IC302	C-12	Q550	H-14		
IC303	0-9	Q551	I-14		
IC304	F-9	Q552	E-13		
IC305	0-7	Q553	G-14		
IC401	C-14	Q599	C-15		
IC402	B-14	Q601	0-3		
IC403	A-14				
IC404	B-14				
IC405	A-14				
IC406	B-12				
IC407	C-12				
IC501	F-14				
IC502	F-16				
IC601	E-8				
MM201	B-7				

DIODE	
0001	H-1
0081	F-1
0082	F-1
0101	A-1
0104	0-1
0106	0-2
0113	J-2
0114	J-2
0115	F-1
0117	C-7
0118	F-4
0119	F-4
0120	G-4
0121	G-4
0128	F-2
0199	I-3
0321	I-8
0350	0-13
0351	0-13
0451	C-15
0452	B-15
0501	F-10
0508	F-13
0511	H-8
0512	G-14
0513	I-12
0514	J-12
0515	H-16
0516	H-16
0517	H-11
0518	G-11
0519	G-13
0597	J-8
0598	C-15
0599	C-14
0601	C-5
0602	0-3

TRANSISTOR	
Q107	I-1
Q108	J-4
Q109	G-1
Q110	G-2
Q112	C-7
Q113	F-4
Q114	G-4
Q115	F-4
Q116	F-4
Q119	F-2
Q120	I-4
Q121	I-4
Q122	J-4
Q123	B-9
Q201	A-11
Q203	B-8
Q205	A-10
Q301	E-14
Q302	0-13
Q303	0-13
Q304	C-13
Q305	0-13
Q306	0-14
Q354	E-13
Q371	E-13
Q398	E-11
Q401	A-13

VARIABLE REGISTER	
RV131	G-4
RV201	A-11
RV299	G-6
RV306	0-10
RV307	0-11
RV361	E-13
RV501	E-12
RV502	E-9
RV503	F-15
RV505	E-16
RV506	G-16
RV507	F-15
RV508	G-16

TEST POINT	
TP12	C-10
TP15	A-10
TP21	A-6
TP47	0-9
TP82	G-14
T084	G-13
TP85	G-9
TP86	H-14
TP87	G-13
TP91	G-9
TP92	0-7
TP92B	G-7
TP93	E-9
TP94	C-8
TP95	G-11
TP96	F-13
TP97	G-11
TP98	B-8
TP99	F-1

**NOTE:**  
The circuit indicated as left contains high voltage of over 600 Vp-p. Care must be paid to prevent an electric shock in inspection or repairing.

**A BOARD WAVEFORM**

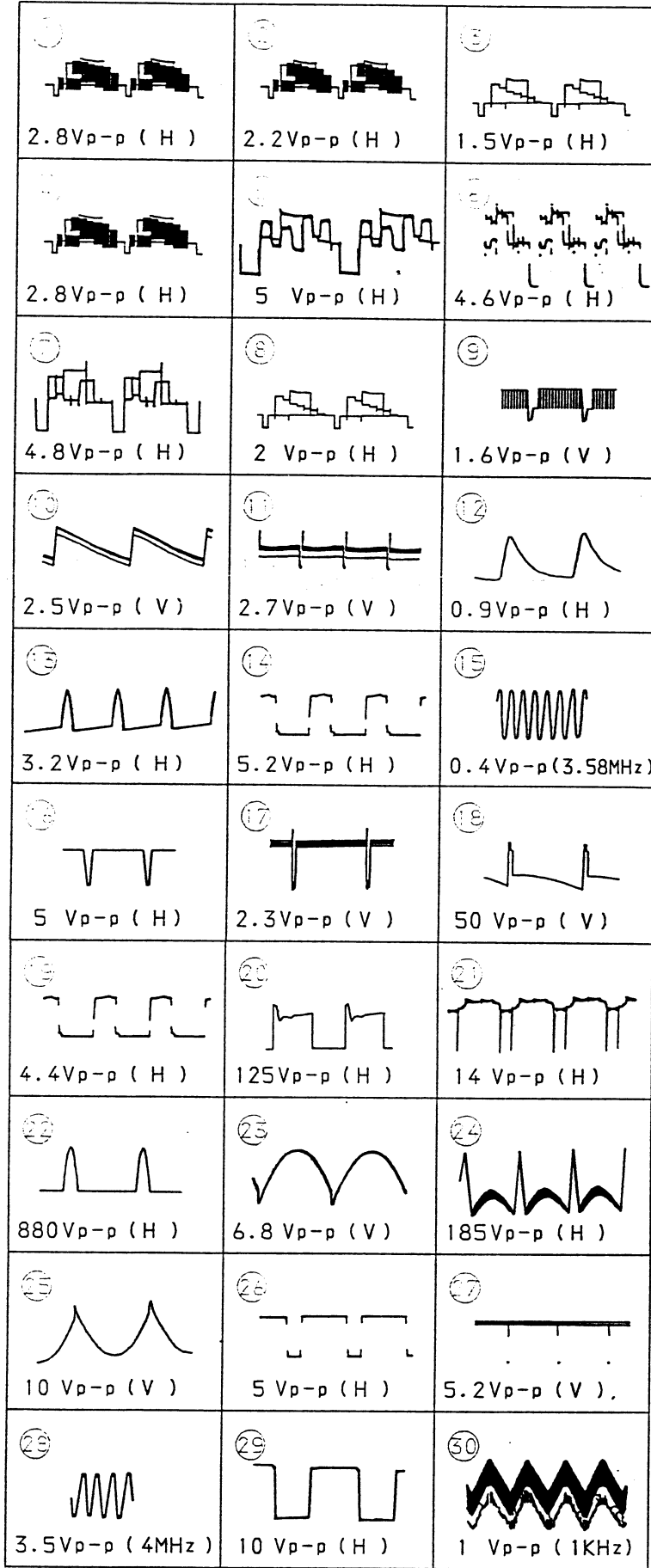

**. A BOARD IC501 uPC1378H-P**

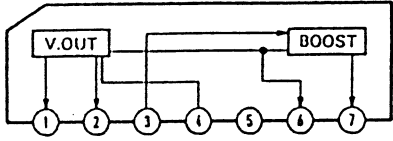

**. A BOARD IC502 uRC4558P**

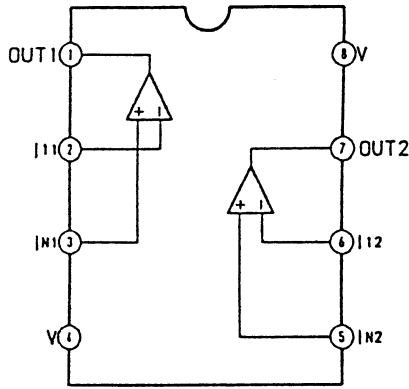

**. A BOARD IC401 IVM-3**

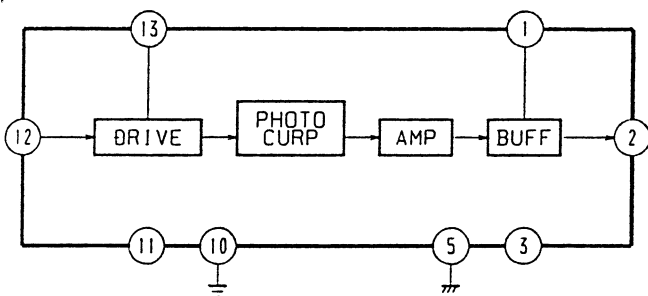

**. A BOARD IC402 IAM-3**

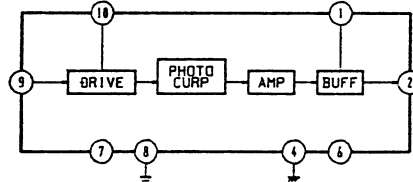

**. A BOARD IC301 CXA1013AS**

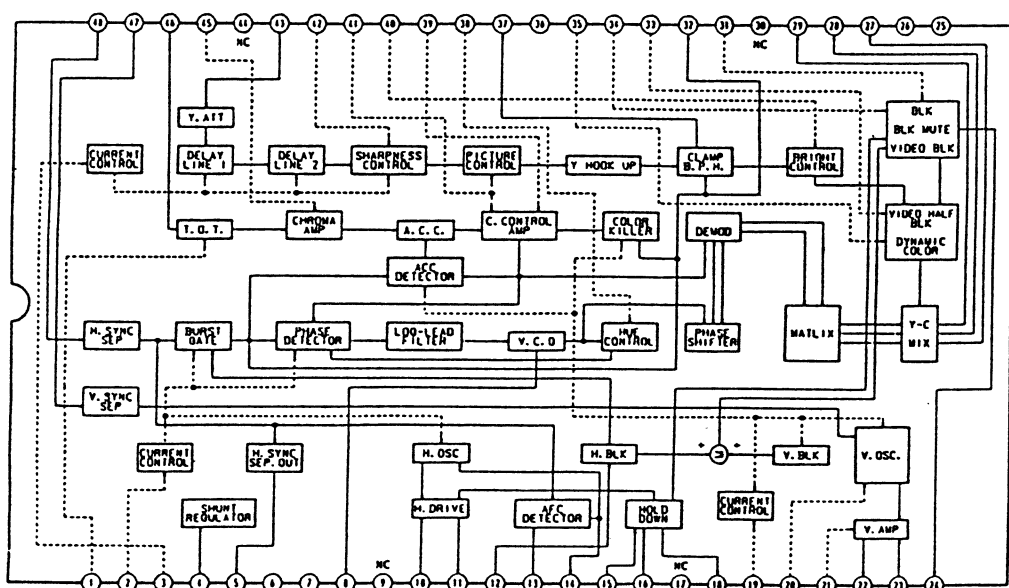

**. A BOARD IC206 SI-4102**

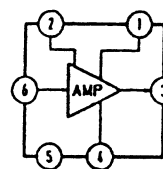

**KV-20TR22**

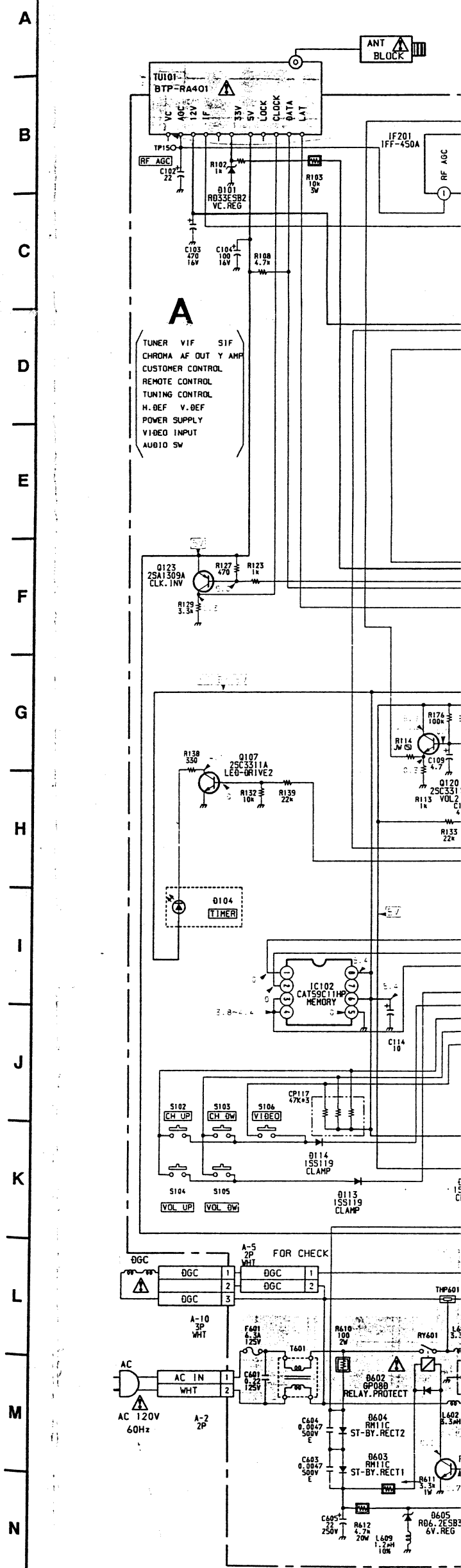

**CAUTION**  
This set equipped with a polarized ac power cord plug (one blade of the plug is wider than the other). When replacing the ac power cord be sure to connect it with specified part number as shown in this diagram.

Channel	Frequency
CH. 5	5.5V±1V
CH. 6	20.5V±1V
CH. 11	25.5V±1V
CH. 15	25.5V±1V

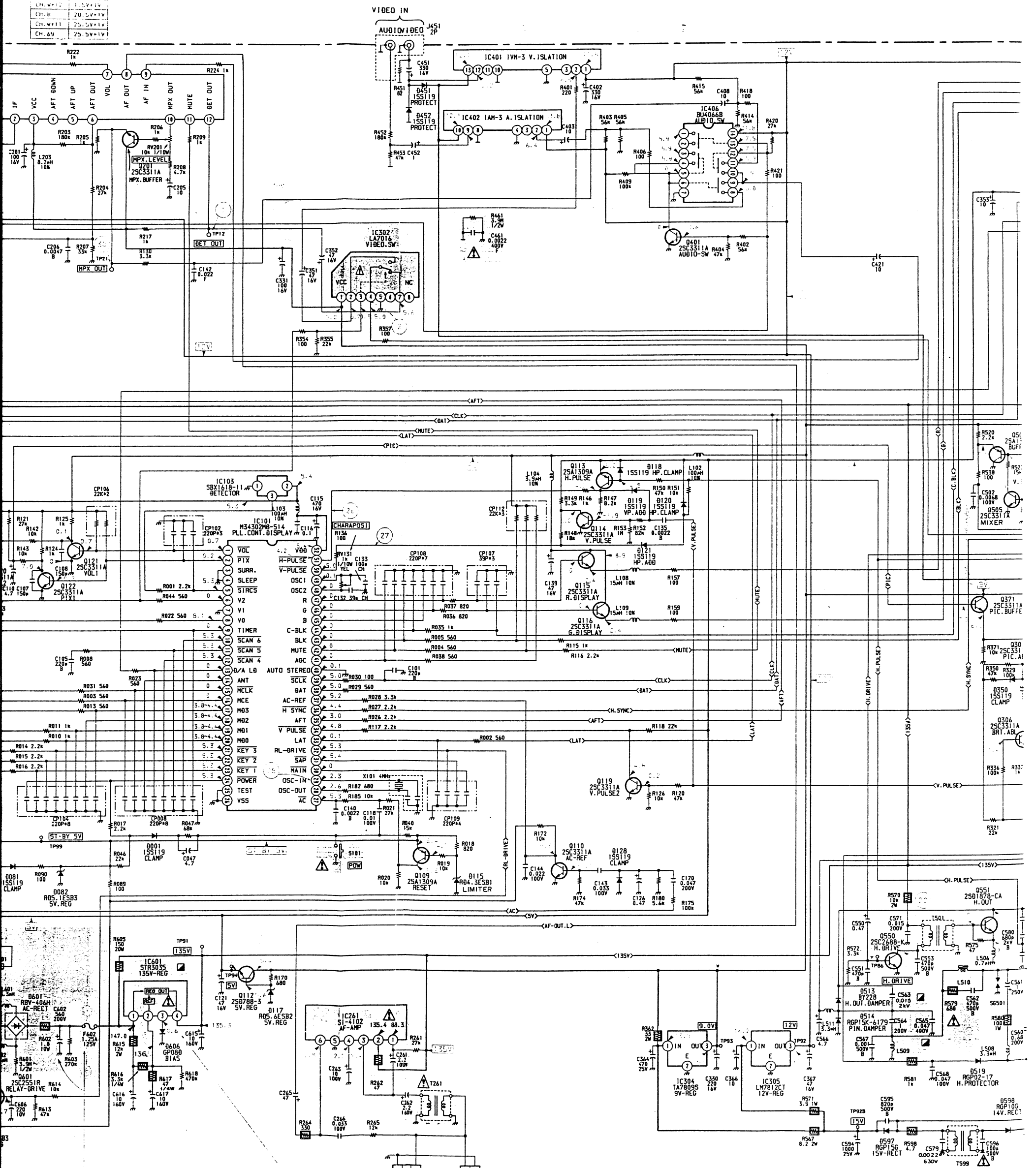

**CAUTION**

When taking a broken fuse (F602) off discharge across C602 to avoid shock hazard.

**CAUTION**

When replacing IC601, be sure to check the test point voltage value (TP91). Refer to the Safety Adjustment Section.

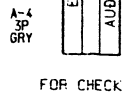

FOR CHECK SP901

When replacing F1 check point voltage Section of the S



KV-20TR22

Tuning Voltage

CHANNEL	VOLTAGE
CH. 2	1.5V+1V
CH. C	1.5V+1V
CH. W+12	1.5V+1V
CH. B	20.5V+1V
CH. W+11	25.5V+1V
CH. 69	25.5V+1V

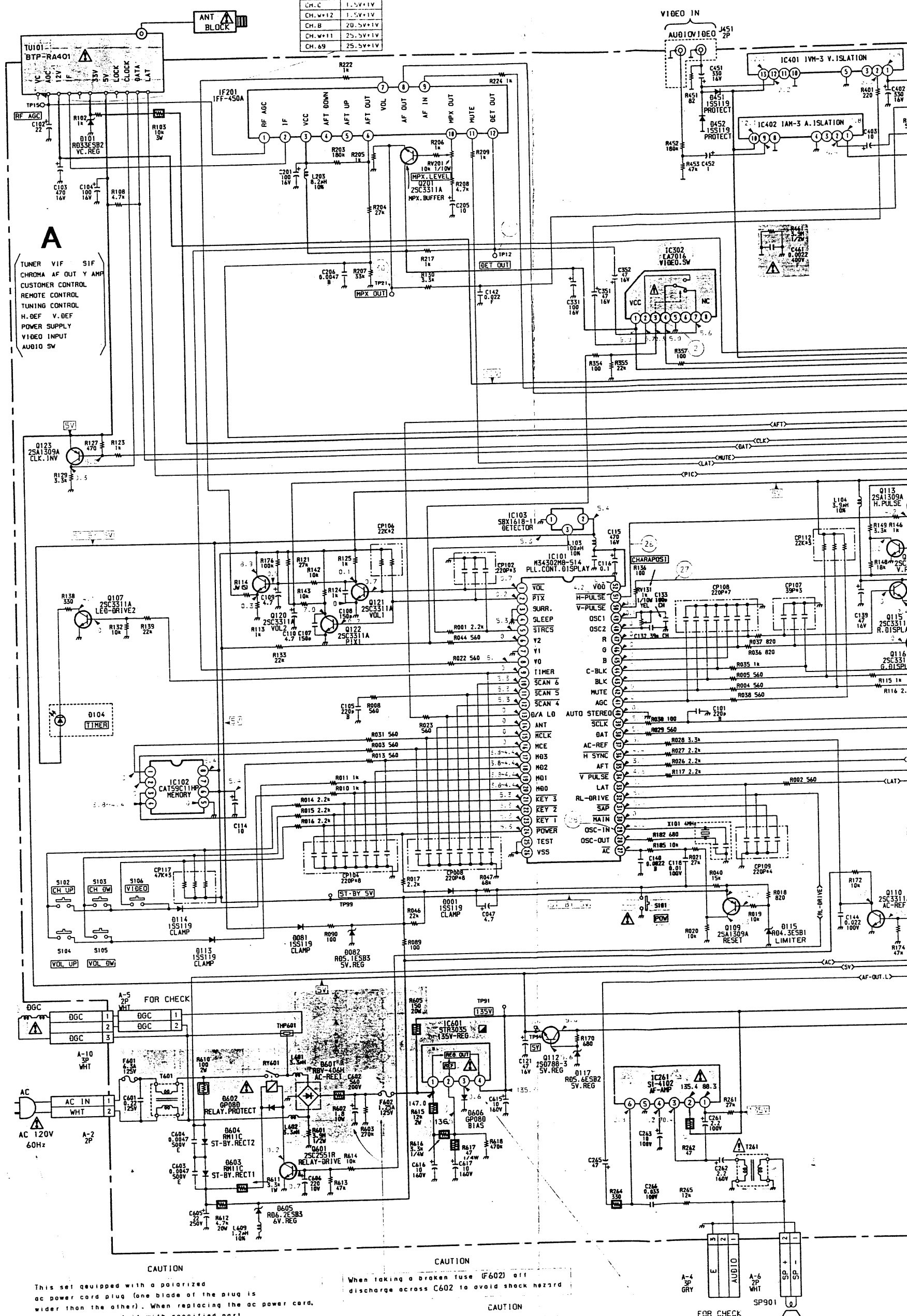

**A**  
 TUNER VIF SIF  
 CHROMA AF OUT Y AMP  
 CUSTOMER CONTROL  
 REMOTE CONTROL  
 TUNING CONTROL  
 H. DEF V. DEF  
 POWER SUPPLY  
 VIDEO INPUT  
 AUDIO SW

FOR CHECK  
 DGC 1 2 3  
 A-5 2P WHT  
 A-10 3P WHT  
 AC IN 1 2  
 A-2 2P

**CAUTION**  
 This set equipped with a polarized ac power cord plug (one blade of the plug is wider than the other). When replacing the ac power cord, be sure to connect it with specified part number as shown in this diagram.

**CAUTION**  
 When taking a broken fuse (F602) out discharge across C602 to avoid shock hazard.

**CAUTION**  
 When replacing IC601, be sure to check the test point voltage value (TP91). Refer to the Satisfy Adjustment Section.

FOR CHECK  
 A-4 3P GRV  
 AUDIO  
 A-6 2P WHT  
 SP901

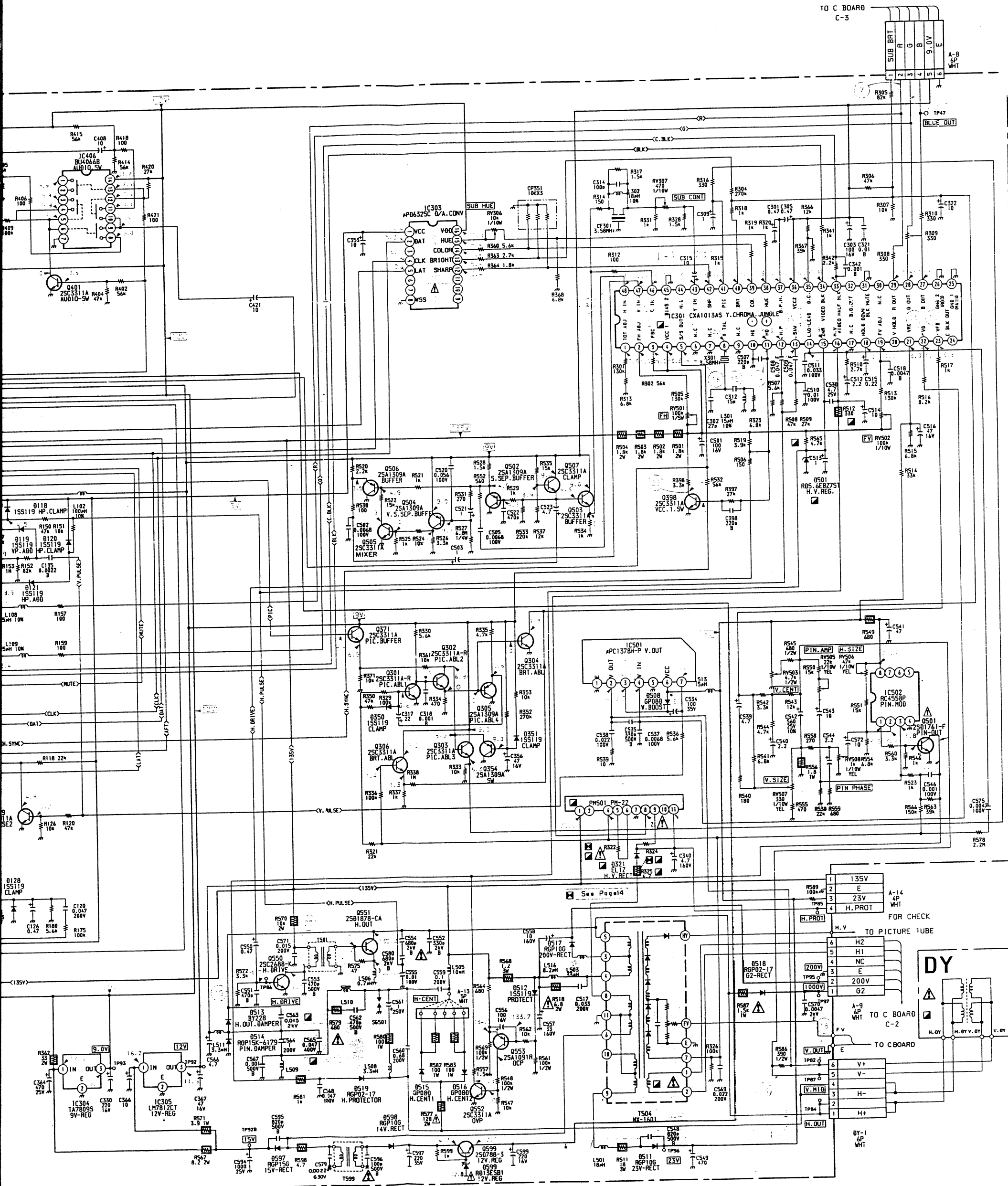

**CAUTION**  
 When replacing FBT (T504), be sure to check the HOLD DOWN check point voltage value. Refer to the Safety Adjustment Section of the Service Manual.

KV-20TS27

Tuning Voltages

Channel	VOLTAG
1	15.5V±1V
2	15.5V±1V
3	15.5V±1V
4	15.5V±1V
5	20.5V±1V
6	20.5V±1V
7	20.5V±1V
8	20.5V±1V
9	20.5V±1V
10	20.5V±1V
11	20.5V±1V

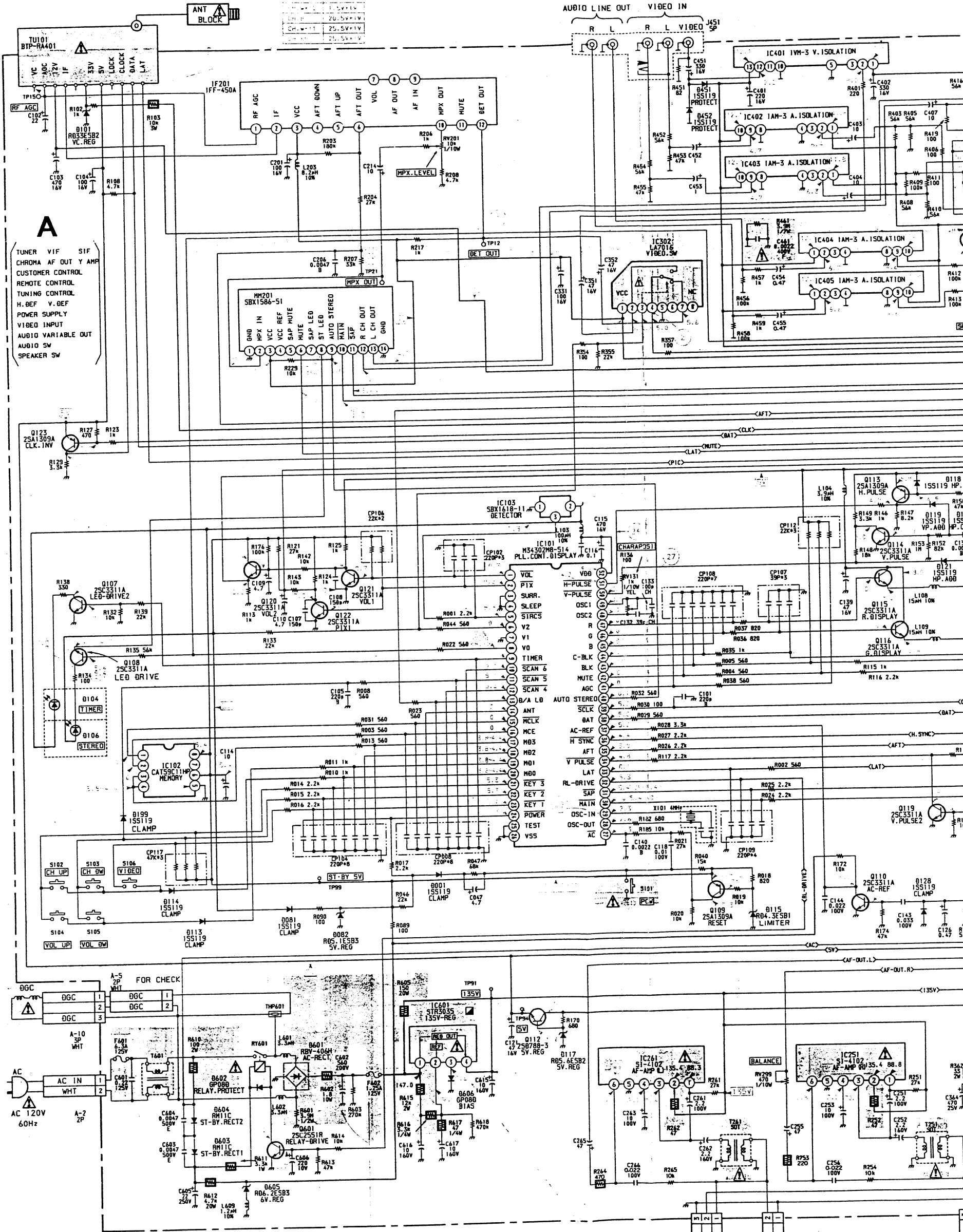

**A**

TUNER VIF SIF  
 CHROMA AF OUT Y AMP  
 CUSTOMER CONTROL  
 REMOTE CONTROL  
 TUNING CONTROL  
 H. DEF V. DEF  
 POWER SUPPLY  
 VIDEO INPUT  
 AUDIO VARIABLE OUT  
 AUDIO SW  
 SPEAKER SW

FOR CHECK

OGC 1 2 3

A-5 2P WHT

A-10 3P WHT

AC IN 1 2

AC 120V 60Hz

A-2 2P

**CAUTION (US MODEL ONLY)**

This set equipped with a polarized ac power cord plug (one blade of the plug is wider than the other). When replacing the ac power cord, be sure to connect it with specified part number as shown in this diagram.

**CAUTION**

When taking a broken fuse (F602) off discharge across C602 to avoid shock hazard.

**CAUTION**

When replacing IC601, be sure to check the test point voltage value (TP91). Refer to the Solly Adjustment Section.

FOR CHECK

A-4 3P GRY

A-6 2P WHT

SP902

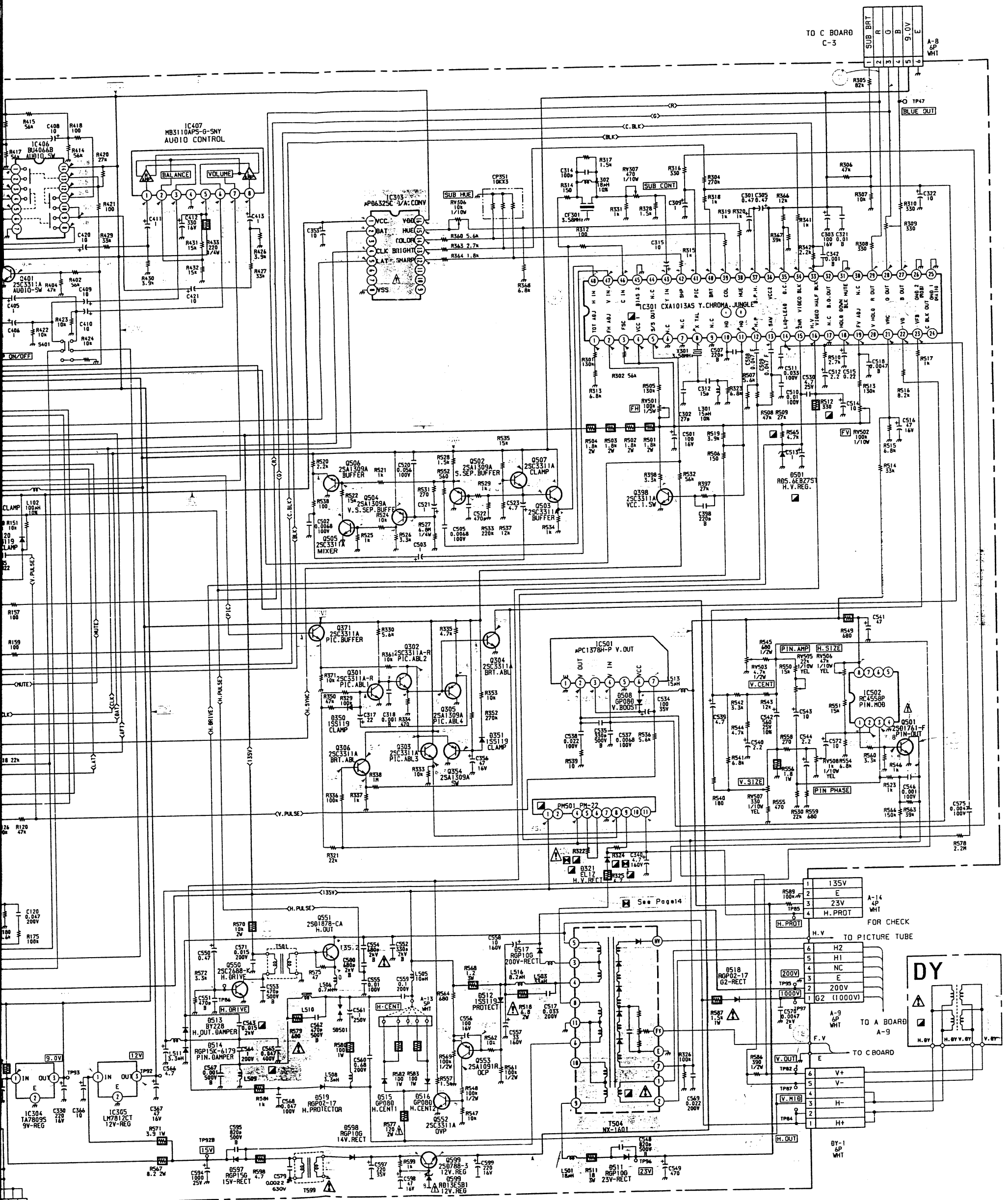

**CAUTION**  
 When replacing FBT (T504), be sure to check the HOLD DOWN check point voltage value. Refer to the Safety Adjustment Section of the Service Manual.

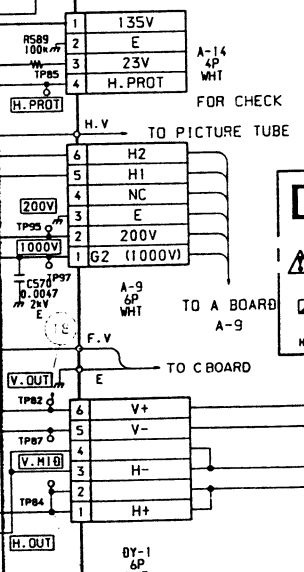



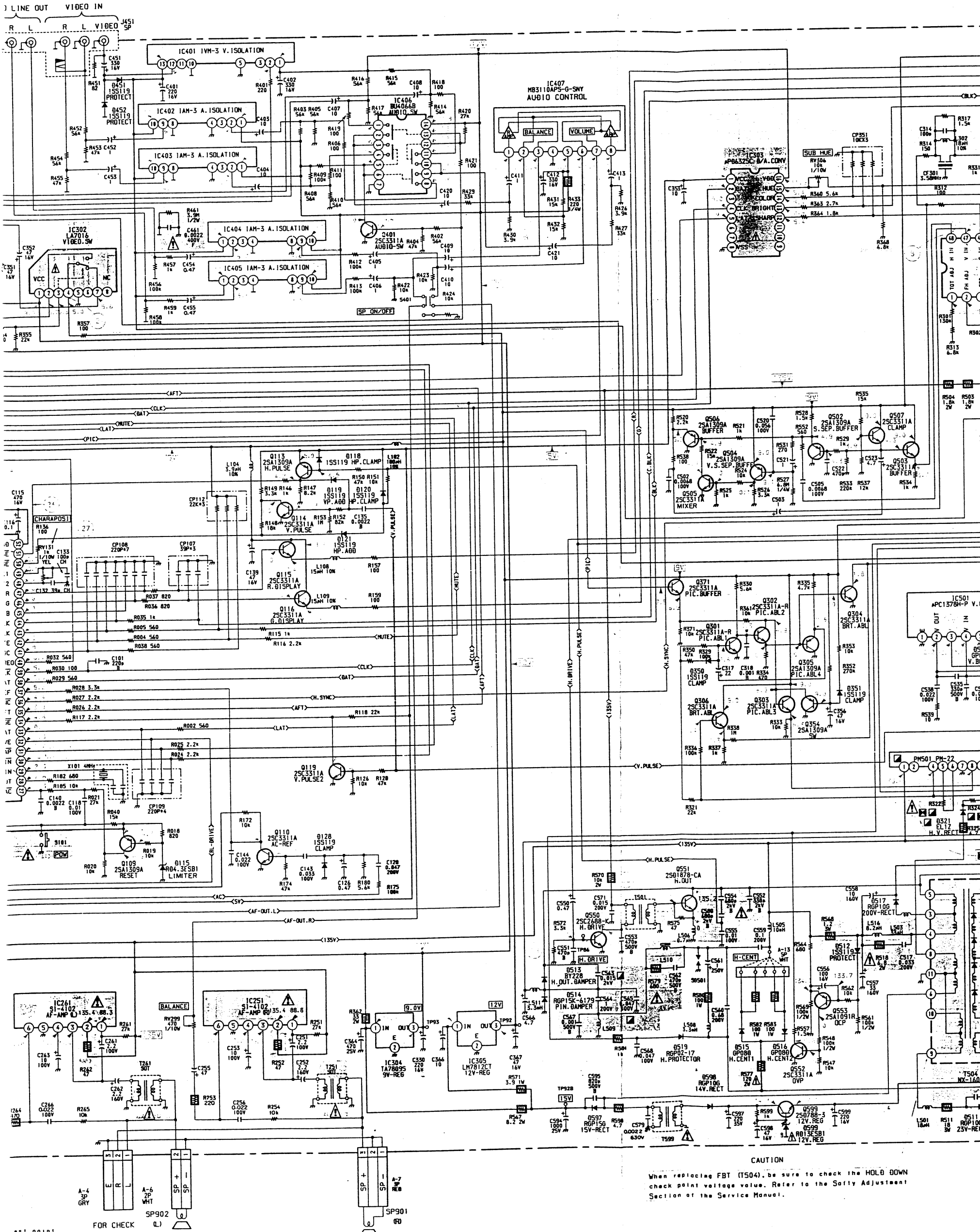

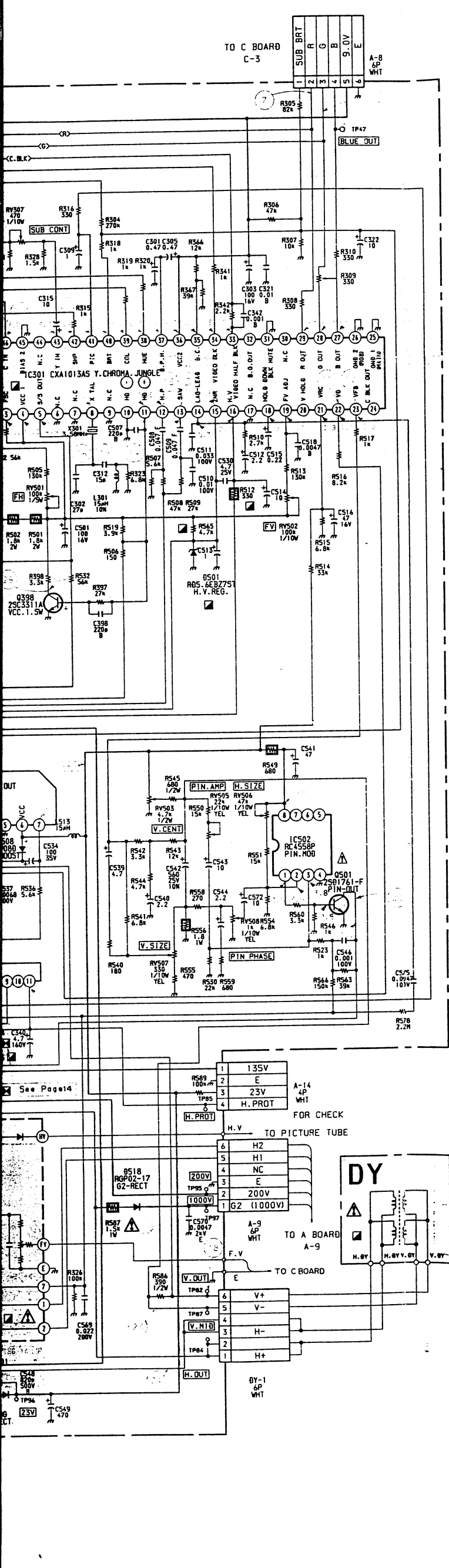

**A BOARD WAVEFORM**

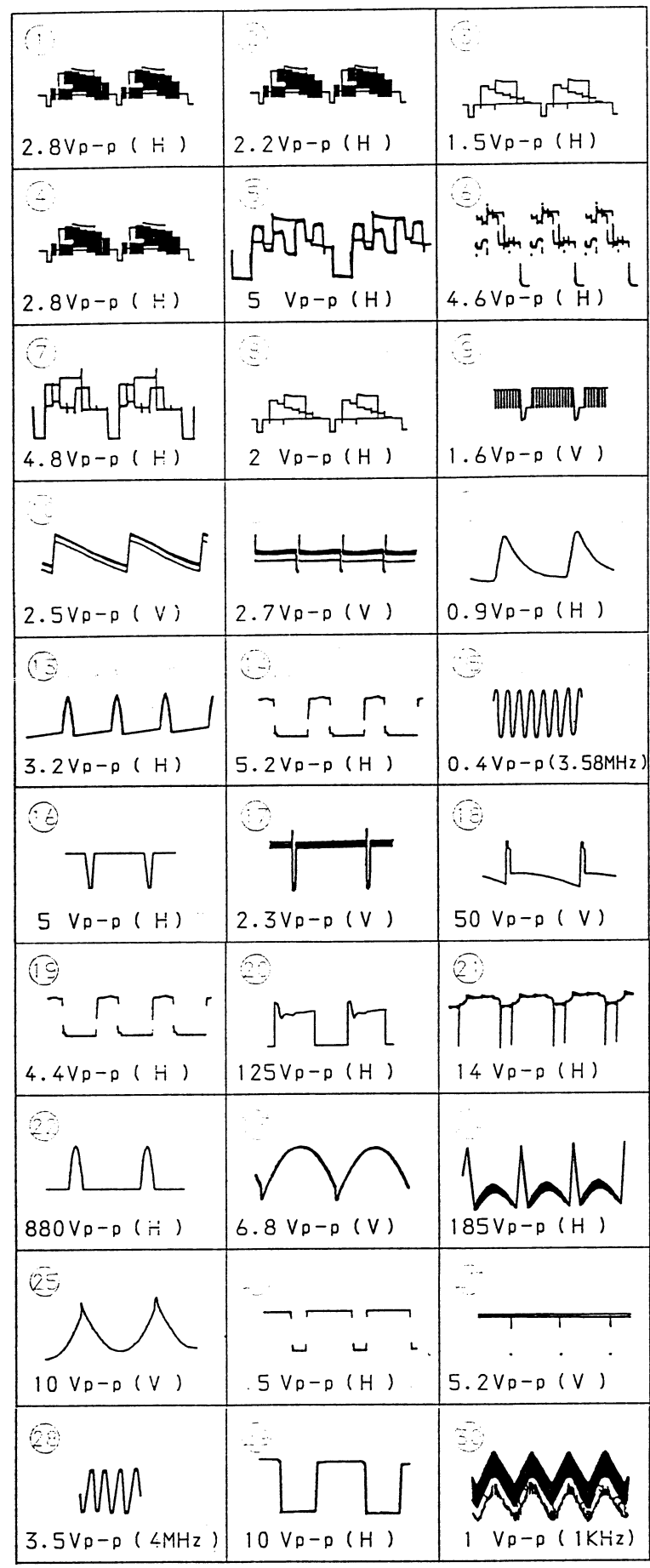

**. A BOARD IC501 uPC1378H-P**

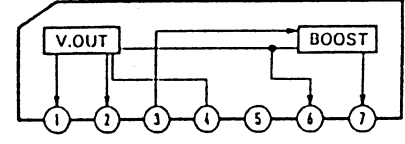

**. A BOARD IC502 uRC4558P**

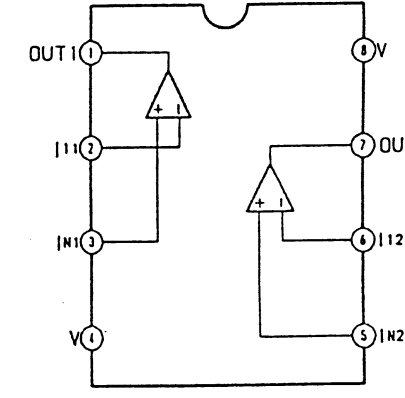

**. A BOARD IC401 IVM-3**

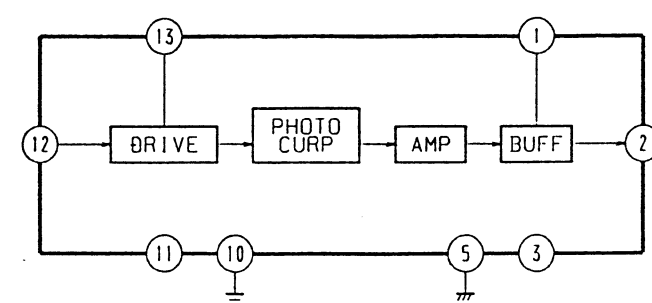

**. A BOARD IC402 IAM-3**

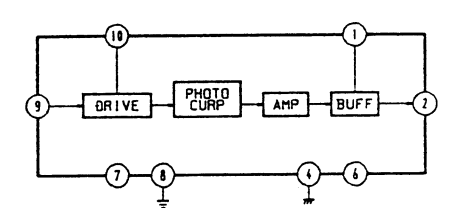

**. A BOARD IC301 CXA1013AS**

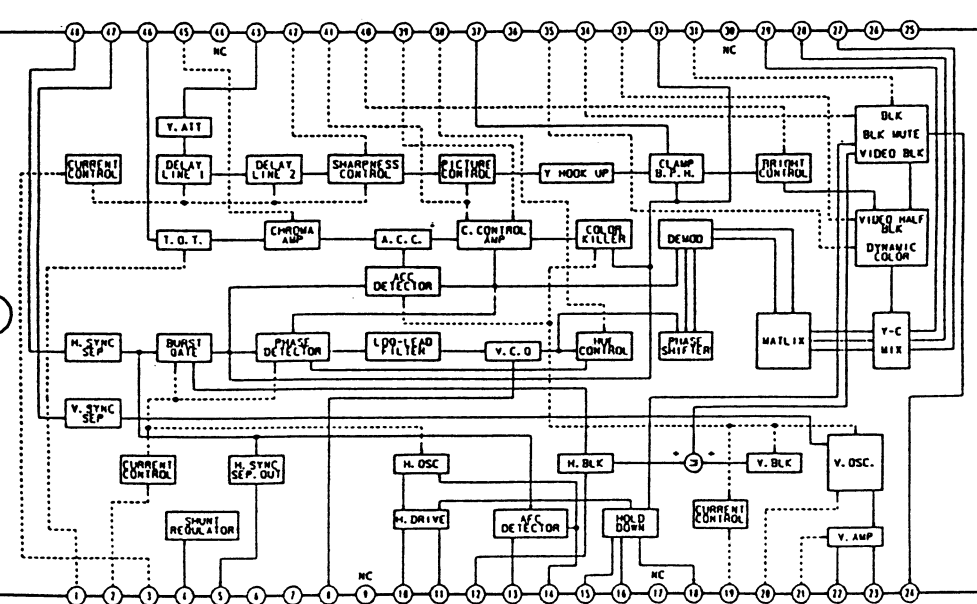

**. A BOARD IC206 SI-4102**

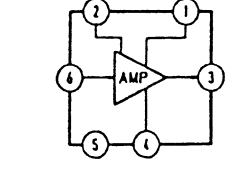

**C** (R.G.B OUT)

— C Board —

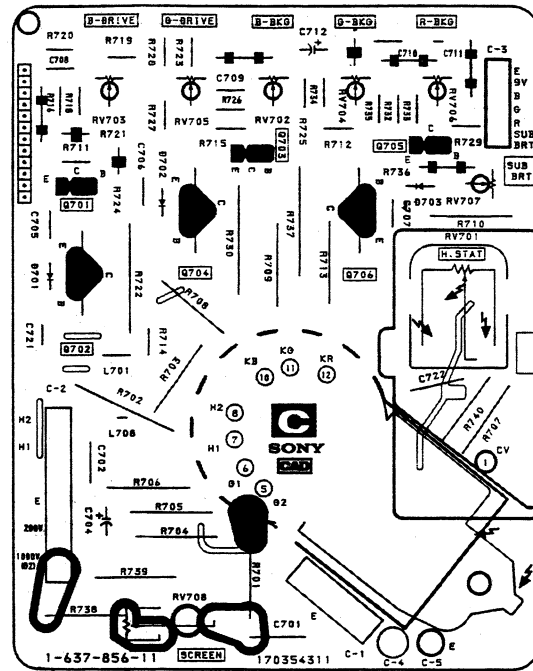

**NOTE:**  
The circuit indicated as left contains high voltage of over 600 Vp-p. Care must be paid to prevent an electric shock in inspection or repairing.

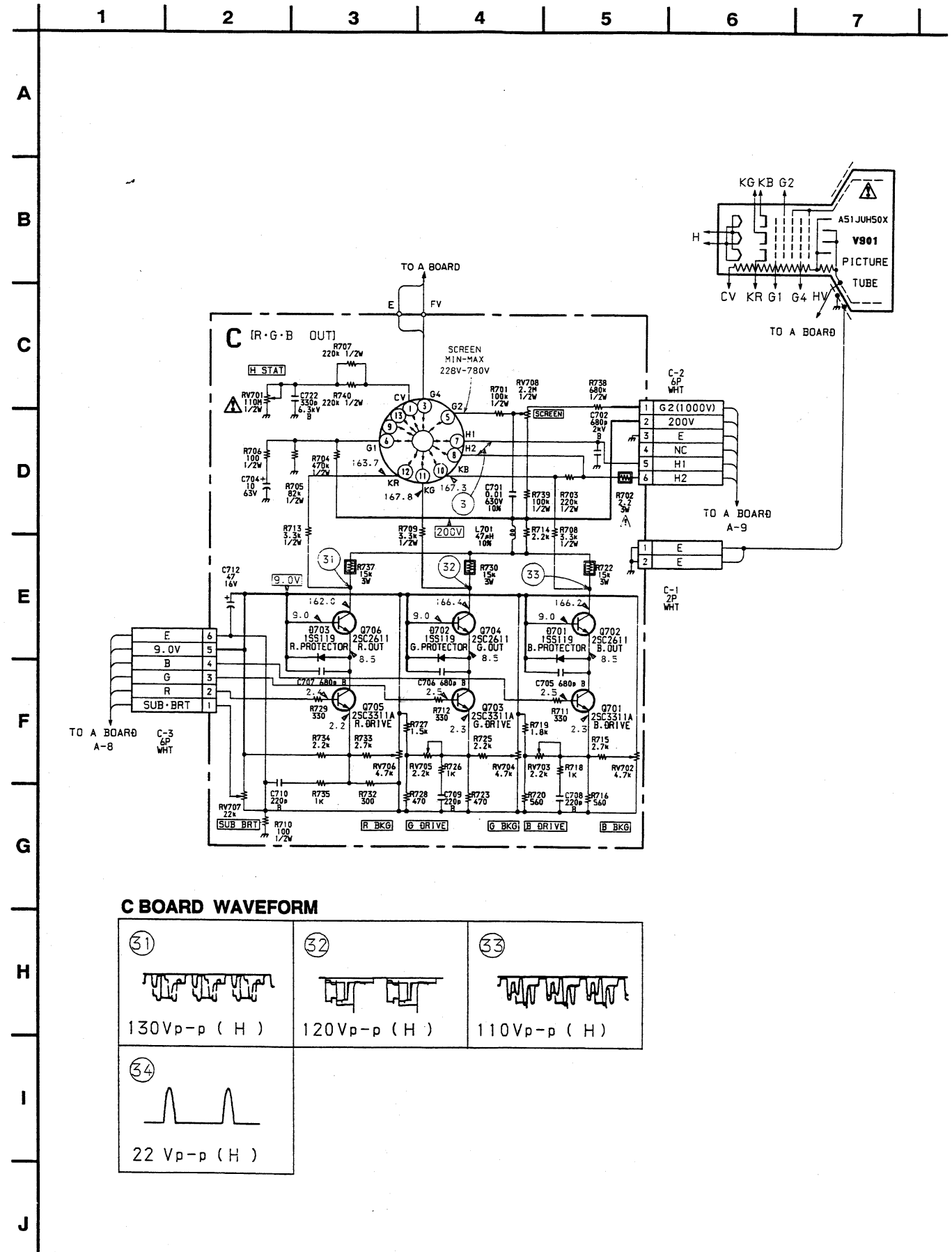

6-3. SEMICONDUCTORS

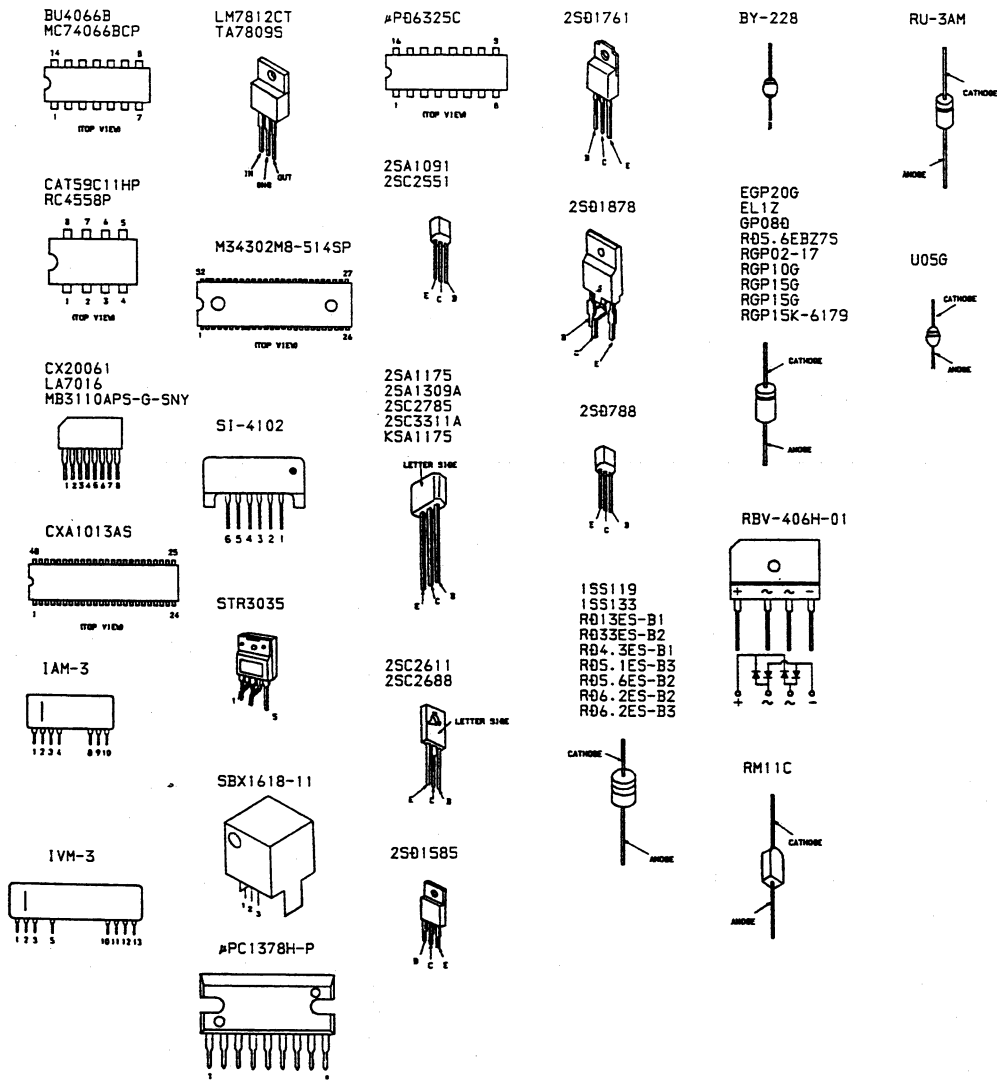

SECTION 7  
EXPLODED VIEWS

NOTE:  
 • Items with no part number and no description are not stocked because they are seldom required for routine service.  
 • The construction parts of an assembled part are indicated with a collation number in the remark column.  
 • Items marked " \* " are not stocked since they are seldom required for routine service. Some delay should be anticipated when ordering these items.

The components identified by shading and mark  $\Delta$  are critical for safety. Replace only with part number specified.

Les composants identifiés par une trame et une marque  $\Delta$  sont critiques pour la sécurité. Ne les remplacer que par une pièce portant le numéro spécifié.

7-1. CHASSIS

- $\Delta$ : BVTP 4x 16 7-685-663-79
- : BVTP 3x 12 7-685-648-79

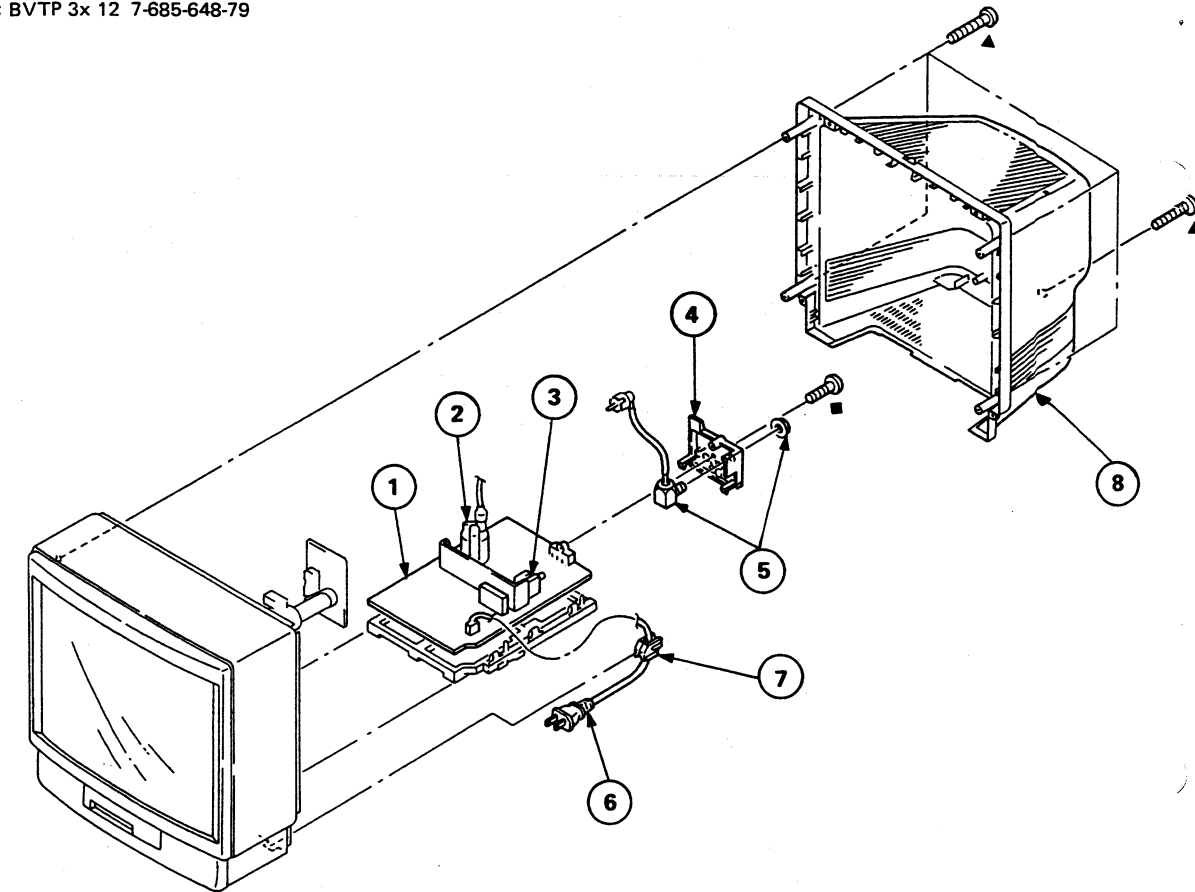

REF. NO.	PART NO.	DESCRIPTION	REMARK	REF. NO.	PART NO.	DESCRIPTION	REM.
1	*A-1296-821-A	A BOARD, COMPLETE (KV-20TR22(U) ONLY)		4	4-031-082-01	TERMINAL BOARD, ANTENNA	
	*A-1296-822-A	A BOARD, COMPLETE (KV-20TS27(U) ONLY)					
	*A-1296-854-A	A BOARD, COMPLETE (KV-20TS27(C) ONLY)			4-031-082-11	TERMINAL BOARD, ANTENNA (KV-20TR22 (U) ON)	
2	$\Delta$ 1-439-416-41	TRANSFORMER ASSY, FLYBACK (NX-1604)		5	$\Delta$ 1-536-678-31	ANTENNA BLOCK	
3	$\Delta$ 1-465-371-11	TUNER, ET (BTP-RA401)					
	$\Delta$ 1-465-371-21	TUNER, ET (BTP-RA401) (KV-20TR22(U), KV-20TS27(U) ONLY)			$\Delta$ 1-537-077-21	ANTENNA BLOCK (KV-20TR22(U), KV-20TS27(U) ON)	
					$\Delta$ 1-590-492-11	CORD, POWER (WITH CONNECTOR)	
				7	$\Delta$ 4-388-328-01	GROMMET, AC CORD	
				8	4-031-087-01	COVER, REAR	



7-2. PICTURE TUBE

■ : BVTP 3x12 7-685-648-79

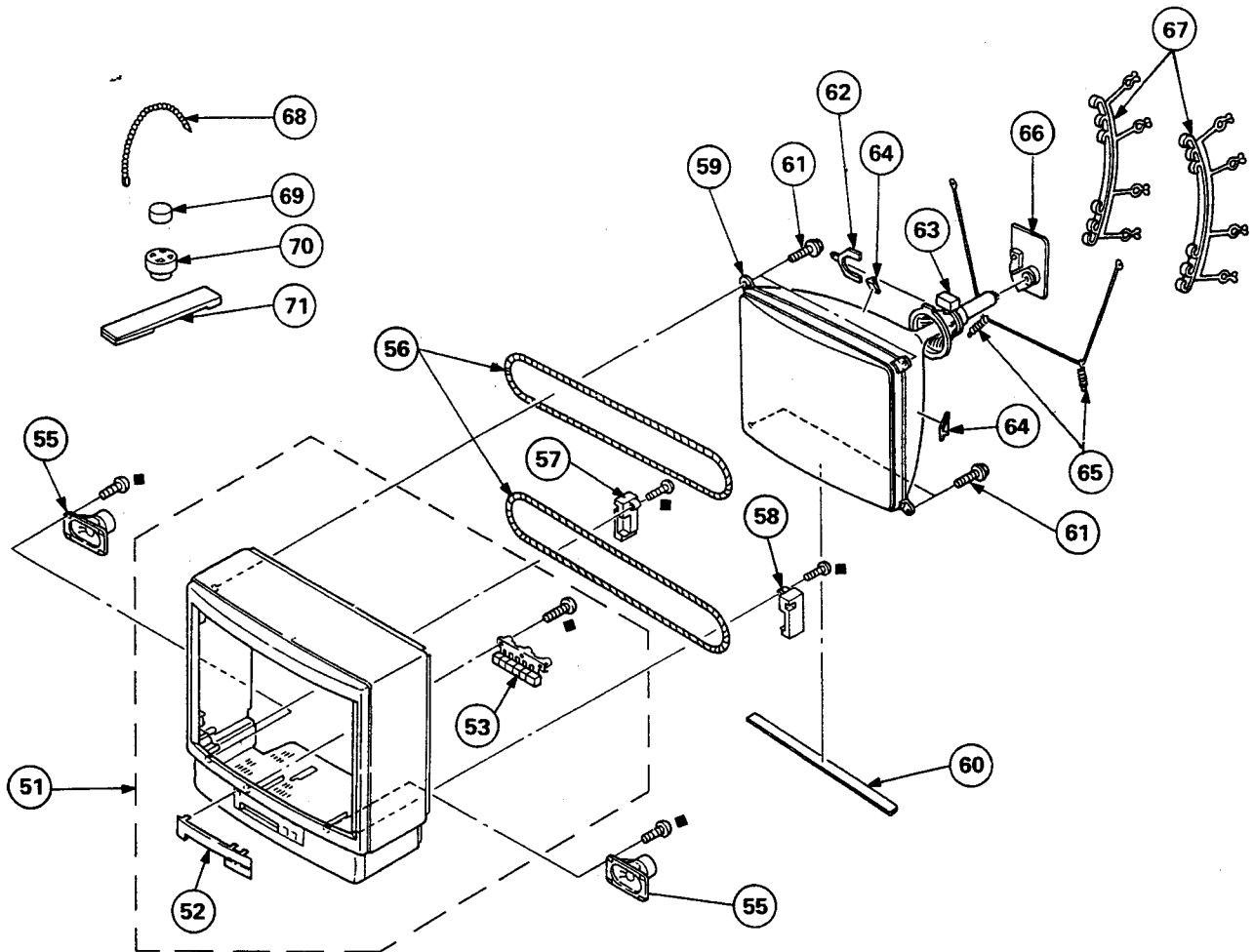

The components identified by shading and mark **▲** are critical for safety. Replace only with part number specified.

Les composants identifiés par une trame et une marque **▲** sont critiques pour la sécurité. Ne les remplacer que par une pièce portant le numéro spécifié.

REF.NO.	PART NO.	DESCRIPTION	REMARK	REF.NO.	PART NO.	DESCRIPTION	REMARK
51	X-4029-435-1	CABINET ASSY (WITH BEZEL ASSY) (KV-20TR22(U) ONLY)	52,53	61	4-307-249-00	SCREW (5), TAPPING	
	X-4029-438-1	CABINET ASSY (WITH BEZEL ASSY) (KV-20TS27(U/C) ONLY)	52,53	62	1-452-277-00	MAGNET, BMC	
52	X-4029-607-1	PANEL ASSY, CONTROL (KV-20TR22 (U) ONLY)		63	▲ 1-451-268-11	DEFLECTION YOKE (Y21PXA)	
	X-4029-606-1	PANEL ASSY, CONTROL (KV-20TS27 (U/C) ONLY)		64	3-704-495-01	SPACER, DY	
53	X-4029-436-1	BUTTON ASSY, MULTI		65	4-375-394-01	SPRING, TENSION	
55	1-544-283-11	SPEAKER		66	*A-1331-126-A	C BOARD, COMPLETE	
56	▲ 1-426-358-11	COIL, DEMAGNETIZATION		67	*4-341-778-21	BAND, DEGAUSSING COIL	
57	4-031-079-01	SUPPORT (LEFT), PICTURE TUBE		68	4-308-870-00	CLIP, LEAD WIRE	
58	4-031-078-01	SUPPORT (RIGHT), PICTURE TUBE		69	1-452-032-00	MAGNET, DISK; 10MM $\phi$	
59	▲ 8-738-752-05	PICTURE TUBE (A51JUH50X)		70	1-452-094-00	MAGNET, ROTATABLE DISK; 15MM $\phi$	
60	4-385-725-01	SHEET, BLOTTING		71	X-4308-815-0	PERMALLOY ASSY, CONVERGENCE	

**A**

**SECTION 8**

**ELECTRICAL PARTS LIST**

NOTE:

The components identified by shading and mark **Δ** are critical for safety. Replace only with part number specified.

Les composants identifiés par une trame et une marque **Δ** sont critiques pour la sécurité. Ne les remplacer que par une pièce portant le numéro spécifié.

• Items marked " \* " are not stocked since they are seldom required for routine service. Some delay should be anticipated when ordering these items.

• All variable and adjustable resistors have characteristic curve B, unless otherwise noted.

**RESISTORS**

• All resistors are in ohms  
 • F : nonflammable

When indicating parts by reference number, please include the board name.

**CAPACITORS**

• MF :  $\mu$ F, PF :  $\mu$ F

**COILS**

• MMH : mH, UH :  $\mu$ H

• The components identified by **☒** in this manual have been carefully factory-selected for each set in order to satisfy regulations regarding X-ray radiation. Should replacement be required, replace only with the value originally used.

• There are some cases the reference number on one board overlaps on the other board. Therefore, when ordering parts by the reference number, please include the board name.

REF.NO.	PART NO.	DESCRIPTION	REMARK	REF.NO.	PART NO.	DESCRIPTION	REMARK
*A-1296-822-A		A BOARD, COMPLETE (KV-20TS27(U) ONLY)					
		*****					
*A-1296-854-A		A BOARD, COMPLETE (KV-20TS27(C) ONLY)					
		*****					
*1-508-765-00		PIN, CONNECTOR (5MM PITCH) 3P		C139	1-124-477-11	ELECT 47MF 20%	16V
*1-508-766-00		PIN, CONNECTOR (5MM PITCH) 4P		C140	1-102-121-00	CERAMIC 0.0022MF 10%	50V
*1-508-767-00		PIN, CONNECTOR (5MM PITCH) 5P		C143	1-106-379-12	MYLAR 0.033MF 10%	100V
*1-508-768-00		PIN, CONNECTOR (5MM PITCH) 6P		C144	1-106-375-12	MYLAR 0.022MF 10%	100V
*1-508-786-00		PIN, CONNECTOR (5MM PITCH) 2P		C201	1-126-101-11	ELECT 100MF 20%	16V
1-533-223-11		CLIP, FUSE		C206	1-102-125-00	CERAMIC 0.0047MF 10%	50V
*1-559-991-21		CONNECTOR ASSY 1P		C214	1-124-907-11	ELECT 10MF 20%	50V
*1-560-123-00		PLUG, CONNECTOR (2.5MM) 3P		C251	1-124-925-11	ELECT 2.2MF 20%	100V
*1-564-505-11		PLUG, CONNECTOR 2P		C252	1-124-799-11	ELECT 2.2MF 20%	160V
*1-564-506-11		PLUG, CONNECTOR 3P		C253	1-124-667-11	ELECT 10MF 20%	100V
*1-564-509-11		PLUG, CONNECTOR 6P		C255	1-124-910-11	ELECT 47MF 20%	50V
*1-568-536-11		PLUG (MINIATURE DY) 6P		C256	1-106-375-12	MYLAR 0.022MF 10%	100V
*1-580-843-11		PIN, CONNECTOR (POWER)		C261	1-124-925-11	ELECT 2.2MF 20%	100V
*4-341-751-01		EYELET (EY1, EY2, EY5, EY6, EY7, EY8, EY9, EY10, EY11, EY12, EY85, EY86, EY87, EY88, EY93, EY94, EY95, EY96, EY97, EY98, EY99, EY113, EY114)		C262	1-124-799-11	ELECT 2.2MF 20%	160V
*4-341-752-01		EYELET (EY50, EY51, EY52, EY53, EY55, EY56, EY57, EY58, EY59, EY60, EY61, EY62, EY63, EY65, EY66, EY67, EY68, EY69, EY91, EY92, EY100, EY101, EY102, EY103, EY104, EY105, EY106, EY107, EY108, EY109, EY110, EY111)		C263	1-124-667-11	ELECT 10MF 20%	100V
*4-363-404-00		HOLDER, IC		C265	1-124-910-11	ELECT 47MF 20%	50V
4-369-267-01		SPACER, MICA		C266	1-106-375-12	MYLAR 0.022MF 10%	100V
				C301	1-124-902-00	ELECT 0.47MF 20%	50V
				C302	1-164-056-11	CERAMIC 27PF 5%	50V
				C303	1-126-101-11	ELECT 100MF 20%	16V
				C305	1-124-902-00	ELECT 0.47MF 20%	50V
				C309	1-124-903-11	ELECT 1MF 20%	50V
				C312	1-164-050-11	CERAMIC 15PF 5%	50V
				C314	1-164-070-11	CERAMIC 100PF 5%	50V
				C315	1-124-907-11	ELECT 10MF 20%	50V
				C317	1-126-233-11	ELECT 22MF 20%	50V
				C318	1-102-074-00	CERAMIC 0.001MF 10%	50V
				C321	1-102-129-00	CERAMIC 0.01MF 10%	50V
				C322	1-124-907-11	ELECT 10MF 20%	50V
				C330	1-124-120-11	ELECT 220MF 20%	16V
				C331	1-126-101-11	ELECT 100MF 20%	16V
				C340	1-123-932-00	ELECT 4.7MF 20%	100V
				C342	1-102-074-00	CERAMIC 0.001MF 10%	50V
				C351	1-124-477-11	ELECT 47MF 20%	16V
				C352	1-124-477-11	ELECT 47MF 20%	16V
				C353	1-124-907-11	ELECT 10MF 20%	50V
				C356	1-124-477-11	ELECT 47MF 20%	16V
				C364	1-124-480-11	ELECT 470MF 20%	20V
				C366	1-124-907-11	ELECT 10MF 20%	50V
				C367	1-124-477-11	ELECT 47MF 20%	16V
				C398	1-164-077-11	CERAMIC 220PF 10%	50V
				C401	1-124-120-11	ELECT 220MF 20%	16V
				C402	1-124-119-00	ELECT 330MF 20%	16V
				C403	1-124-907-11	ELECT 10MF 20%	50V
				C404	1-124-907-11	ELECT 10MF 20%	50V
				C405	1-124-903-11	ELECT 1MF 20%	50V
				C406	1-124-903-11	ELECT 1MF 20%	50V
				C407	1-124-907-11	ELECT 10MF 20%	50V
				C408	1-124-907-11	ELECT 10MF 20%	50V
				C409	1-124-907-11	ELECT 10MF 20%	50V
<CAPACITOR>							
C047	1-124-927-11	ELECT 4.7MF 20%	50V				
C101	1-164-077-11	CERAMIC 220PF 10%	50V				
C102	1-126-233-11	ELECT 22MF 20%	50V				
C103	1-126-103-11	ELECT 470MF 20%	16V				
C104	1-126-101-11	ELECT 100MF 20%	16V				
C105	1-164-077-11	CERAMIC 220PF 10%	50V				
C107	1-101-361-00	CERAMIC 150PF 5%	50V				
C108	1-101-361-00	CERAMIC 150PF 5%	50V				
C109	1-124-927-11	ELECT 4.7MF 20%	50V				
C110	1-124-927-11	ELECT 4.7MF 20%	50V				
C114	1-124-907-11	ELECT 10MF 20%	50V				
C115	1-126-103-11	ELECT 470MF 20%	16V				
C116	1-136-165-00	FILM 0.1MF 5%	50V				
C118	1-106-367-00	MYLAR 0.01MF 10%	100V				
C120	1-106-383-00	MYLAR 0.047MF 200V					
C121	1-124-477-11	ELECT 47MF 20%	16V				
C126	1-124-902-00	ELECT 0.47MF 20%	50V				
C132	1-164-033-11	CERAMIC 39PF 5%	50V				
C133	1-102-973-00	CERAMIC 100PF 5%	50V				
C135	1-102-121-00	CERAMIC 0.0022MF 10%	50V				

The components identified by shading and mark  $\Delta$  are critical for safety. Replace only with part number specified.

Les composants identifiés par une trame et une marque  $\Delta$  sont critiques pour la sécurité. Ne les remplacer que par une pièce portant le numéro spécifié.

A

REF.NO.	PART NO.	DESCRIPTION	REMARK	REF.NO.	PART NO.	DESCRIPTION	REMARK
C410	1-124-907-11	ELECT	10MF 20% 50V	C568 $\Delta$	1-106-383-00	MYLAR	0.047MF 10% 100V
C411	1-124-903-11	ELECT	1MF 20% 50V	C569	1-106-375-12	MYLAR	0.022MF 200V
C412	1-124-119-00	ELECT	330MF 20% 16V	C570	1-162-114-00	CERAMIC	0.0047MF 2KV
C413	1-124-903-11	ELECT	1MF 20% 50V	C571	1-106-371-00	MYLAR	0.015MF 200V
C420	1-124-907-11	ELECT	10MF 20% 50V	C572	1-124-907-11	ELECT	10MF 20% 50V
C421	1-124-907-11	ELECT	10MF 20% 50V	C575	1-106-359-00	MYLAR	0.0047MF 10% 100V
C451	1-124-119-00	ELECT	330MF 20% 16V	C579	1-129-898-00	FILM	0.0022MF 5% 630V
C452	1-124-903-11	ELECT	1MF 20% 50V	C580	1-162-116-00	CERAMIC	680PF 10% 2KV
C453	1-124-903-11	ELECT	1MF 20% 50V	C594	1-124-557-11	ELECT	1000MF 20% 25V
C454	1-124-902-00	ELECT	0.47MF 20% 50V	C595	1-102-212-00	CERAMIC	820PF 10% 500V
C455	1-124-902-00	ELECT	0.47MF 20% 50V	C596	1-162-117-00	CERAMIC	100PF 10% 500V
C461 $\Delta$	1-161-742-00	CERAMIC	0.0022MF 20% 400V	C597	1-124-484-11	ELECT	220MF 20% 35V
C501	1-126-101-11	ELECT	100MF 20% 16V	C598	1-124-477-11	ELECT	47MF 20% 16V
C502	1-106-363-00	MYLAR	0.0068MF 10% 100V	C599	1-124-120-11	ELECT	220MF 20% 16V
C503	1-124-903-11	ELECT	1MF 20% 50V	C601 $\Delta$	1-108-745-52	MYLAR	0.22MF 20% 125V
C505	1-106-363-00	MYLAR	0.0068MF 10% 100V	C602 $\Delta$	1-125-679-31	ELECT	560MF 20% 200V
C507	1-164-077-11	CERAMIC	220PF 10% 50V	C603	1-161-830-00	CERAMIC	0.0047MF 500V
C508	1-101-006-00	CERAMIC	0.047MF 50V	C604	1-161-830-00	CERAMIC	0.0047MF 500V
C509	1-101-006-00	CERAMIC	0.047MF 50V	C605	1-123-948-00	ELECT	22MF 20% 250V
C510	1-106-367-00	MYLAR	0.01MF 10% 100V	C606	1-126-176-11	ELECT	220MF 20% 10V
C511	1-106-379-12	MYLAR	0.033MF 10% 100V	C615	1-124-046-00	ELECT	10MF 20% 160V
C512	1-124-925-11	ELECT	2.2MF 20% 50V	C616	1-124-046-00	ELECT	10MF 20% 160V
C513	1-124-903-11	ELECT	1MF 20% 50V	C617	1-124-046-00	ELECT	10MF 20% 160V
C514	1-124-907-11	ELECT	10MF 20% 50V			<FILTER>	
C515	1-124-464-11	ELECT	0.22MF 20% 50V	CF301	1-409-344-00	CERAMIC TRAP	3.58MHZ
C516	1-124-477-11	ELECT	47MF 20% 16V			<COMPOSITION CIRCUIT BLOCK>	
C517 $\Delta$	1-108-427-91	MYLAR	0.033MF 10% 200V	CP008	1-233-147-11	COMPOSITION CIRCUIT BLOCK	
C518	1-102-125-00	CERAMIC	0.0047MF 10% 50V	CP102	1-233-145-11	COMPOSITION CIRCUIT BLOCK	
C520	1-106-385-00	MYLAR	0.056MF 10% 100V	CP104	1-233-147-11	COMPOSITION CIRCUIT BLOCK	
C521	1-124-903-11	ELECT	1MF 20% 50V	CP106	1-236-357-11	NETWORK, RES	
C522	1-102-824-00	CERAMIC	470PF 5% 50V	CP107	1-233-146-11	COMPOSITION CIRCUIT BLOCK	
C523	1-124-927-11	ELECT	4.7MF 20% 50V	CP108	1-233-118-11	COMPOSITION CIRCUIT BLOCK	
C530	1-124-277-11	ELECT	4.7MF 20% 25V	CP109	1-233-117-11	COMPOSITION CIRCUIT BLOCK	
C534	1-124-122-11	ELECT	100MF 20% 35V	CP112	1-236-490-11	NETWORK, RES, THICK FILM	
C535	1-102-030-00	CERAMIC	330PF 10% 500V	CP117	1-236-078-11	NETWORK, RES, THICK FILM	
C537	1-106-363-00	MYLAR	0.0068MF 10% 100V	CP351	1-236-253-11	NETWORK, RES, THICK FILM	
C538	1-106-375-12	MYLAR	0.022MF 10% 100V			<DIODE>	
C539	1-124-927-11	ELECT	4.7MF 20% 50V	D001	8-719-911-19	DIODE 1SS119	
C540	1-124-925-11	ELECT	2.2MF 20% 50V	D081	8-719-911-19	DIODE 1SS119	
C541	1-124-910-11	ELECT	47MF 20% 50V	D082	8-719-109-86	DIODE RD5.1ES-B3	
C542	1-123-587-00	ELECT	560MF 10% 25V	D101	8-719-110-78	DIODE RD33ES-B2	
C543	1-124-907-11	ELECT	10MF 20% 50V	D104	1-809-401-11	LED UNIT	
C544	1-124-925-11	ELECT	2.2MF 20% 50V	D106	1-809-401-11	LED UNIT	
C546	1-106-343-00	MYLAR	0.001MF 10% 100V	D113	8-719-911-19	DIODE 1SS119	
C548 $\Delta$	1-102-212-00	CERAMIC	820PF 10% 500V	D114	8-719-911-19	DIODE 1SS119	
C549	1-124-913-11	ELECT	470MF 20% 50V	D115	8-719-109-74	DIODE RD4.3ES-B1	
C550	1-124-902-00	ELECT	0.47MF 20% 50V	D117	8-719-109-89	DIODE RD5.6ES-B2	
C551	1-164-081-11	CERAMIC	470PF 10% 50V	D118	8-719-911-19	DIODE 1SS119	
C552 $\Delta$	1-162-115-91	CERAMIC	330PF 10% 2KV	D119	8-719-911-19	DIODE 1SS119	
C553	1-102-228-00	CERAMIC	470PF 10% 500V	D120	8-719-911-19	DIODE 1SS119	
C554 $\Delta$	1-162-116-00	CERAMIC	680PF 10% 2KV	D121	8-719-911-19	DIODE 1SS119	
C555 $\Delta$	1-106-367-00	MYLAR	0.01MF 10% 100V	D128	8-719-911-19	DIODE 1SS119	
C556	1-126-101-11	ELECT	100MF 20% 16V	D199	8-719-911-19	DIODE 1SS119	
C557	1-123-024-21	ELECT	33MF 160V	D321	8-719-302-43	DIODE EL1Z	
C558	1-124-046-00	ELECT	10MF 20% 160V	D350	8-719-911-19	DIODE 1SS119	
C559	1-106-391-12	MYLAR	0.1MF 10% 200V	D351	8-719-911-19	DIODE 1SS119	
C560	1-136-109-00	FILM	0.68MF 5% 200V	D451	8-719-911-19	DIODE 1SS119	
C561	1-124-634-11	ELECT	1MF 20% 250V				
C562 $\Delta$	1-102-228-91	CERAMIC	470PF 10% 500V				
C563 $\Delta$	1-137-231-11	FILM	0.015MF 3% 2KV				
C564 $\Delta$	1-136-111-11	FILM	1MF 5% 200V				
C565 $\Delta$	1-136-313-51	FILM	0.047MF 5% 400V				
C566	1-126-163-11	ELECT	4.7MF 20% 50V				
C567 $\Delta$	1-162-318-11	CERAMIC	0.001MF 10% 500V				

A

Les composants identifiés par une trame et une marque  $\Delta$  sont critiques pour la sécurité. Ne les remplacer que par une pièce portant le numéro spécifié.

The components identified by shading and mark  $\Delta$  are critical for safety. Replace only with part number specified.

REF. NO.	PART NO.	DESCRIPTION	REMARK	REF. NO.	PART NO.	DESCRIPTION	REMARK
D452	8-719-911-19	DIODE ISS119		L104	1-408-404-00	INDUCTOR 3.9UH	
D501	8-719-109-89	DIODE RD5.6ES-B2		L108	1-408-411-00	INDUCTOR 15UH	
D508	8-719-911-55	DIODE U05G		L109	1-408-411-00	INDUCTOR 15UH	
D511 $\Delta$	8-719-300-33	DIODE RU-3AM		L203	1-408-408-00	INDUCTOR 8.2UH	
D512 $\Delta$	8-719-911-19	DIODE ISS119		L301	1-408-411-00	INDUCTOR 15UH	
D513	8-719-988-57	DIODE BY228		L302	1-408-412-00	INDUCTOR 18UH	
D514	8-719-988-55	DIODE RGP15K-6179		L501 $\Delta$	1-410-666-31	INDUCTOR 18UH	
D515	8-719-911-55	DIODE U05G		L503 $\Delta$	1-410-669-31	INDUCTOR 33UH	
D516	8-719-911-55	DIODE U05G		L505	1-459-104-00	COIL, DUST CORE	
D517	8-719-300-33	DIODE RU-3AM		L506	1-407-365-00	COIL, CHOKE	
D518 $\Delta$	8-719-976-64	DIODE RGP02-17		L508	1-412-553-11	INDUCTOR 3.3MMH	
D519	8-719-976-64	DIODE RGP02-17		L509 $\Delta$	1-459-390-31	COIL (WITH CORE)	
D597	8-719-979-85	DIODE EGP20G		L510 $\Delta$	1-459-626-12	HLC	
D598	8-719-300-33	DIODE RU-3AM		L511	1-459-075-00	COIL, DYNAMIC CONVERSION CHOKE	
D599 $\Delta$	8-719-110-35	DIODE RD13ES-B1		L513	1-410-665-31	INDUCTOR 15UH	
D601 $\Delta$	8-719-305-07	DIODE RBV-406H		L516 $\Delta$	1-412-524-21	INDUCTOR 8.2UH	
D602 $\Delta$	8-719-908-03	DIODE GP08D		L601 $\Delta$	1-412-519-21	INDUCTOR 3.3UH	
D603	8-719-304-63	DIODE RM11C		L602 $\Delta$	1-412-519-21	INDUCTOR 3.3UH	
D604	8-719-304-63	DIODE RM11C		L609	1-408-398-00	INDUCTOR 1.2UH	
D605	8-719-109-93	DIODE RD6.2ES-B2					
D606	8-719-911-55	DIODE U05G					
		<FUSE>					
F601 $\Delta$	1-532-748-11	FUSE, GLASS TUBE 6.3A/125V					
F602 $\Delta$	1-532-741-11	FUSE, GLASS TUBE 1.25A/125V					
		<IC>					
IC101	8-759-636-45	IC M34302M8-514SP					
IC102	8-759-748-69	IC CAT59C11HP					
IC103	8-741-618-11	IC SBX1618-11					
IC251 $\Delta$	8-749-900-15	IC SI-4102					
IC261 $\Delta$	8-749-900-15	IC SI-4102					
IC301	8-752-031-72	IC CXA1013AS					
IC302 $\Delta$	8-759-800-81	IC LA7016					
IC303 $\Delta$	8-759-104-05	IC UPD6325C					
IC304	8-759-231-56	IC TA7809S					
IC305	8-759-929-62	IC LM7812CT					
IC401	1-809-366-11	INSULATING MODULE, VIDEO					
IC402	1-809-365-11	INSULATING MODULE, AUDIO					
IC403	1-809-365-11	INSULATING MODULE, AUDIO					
IC404	1-809-365-11	INSULATING MODULE, AUDIO					
IC405	1-809-365-11	INSULATING MODULE, AUDIO					
IC406	8-759-932-33	IC BU4066B					
IC407	8-759-983-38	IC MB3110APS-G-SNY					
IC501	8-759-105-82	IC UPC1378H-P					
IC502	8-759-945-58	IC RC4558P					
IC601 $\Delta$	8-749-930-35	IC STR3035					
MM201	8-741-156-80	IC SBX1568-51					
		<IF BLOCK>					
IF201	1-464-756-21	IF BLOCK (IFF-450A)					
		<JACK>					
J451	1-569-355-11	JACK BLOCK, PIN 5P					
		<COIL>					
L102	1-408-421-00	INDUCTOR 100UH					
L103	1-408-421-00	INDUCTOR 100UH					
		<MODULE>					
PM501	1-809-335-11	MODULE, PROTECTOR (PM-22)					
		<TRANSISTOR>					
Q107	8-729-423-37	TRANSISTOR 2SC3311A-QRS					
Q108	8-729-423-37	TRANSISTOR 2SC3311A-QRS					
Q109	8-729-423-44	TRANSISTOR 2SA1309A-QRS					
Q110	8-729-423-37	TRANSISTOR 2SC3311A-QRS					
Q112	8-729-378-84	TRANSISTOR 2SD788-5					
Q113	8-729-423-44	TRANSISTOR 2SA1309A-QRS					
Q114	8-729-423-37	TRANSISTOR 2SC3311A-QRS					
Q115	8-729-423-37	TRANSISTOR 2SC3311A-QRS					
Q116	8-729-423-37	TRANSISTOR 2SC3311A-QRS					
Q119	8-729-423-37	TRANSISTOR 2SC3311A-QRS					
Q120	8-729-423-37	TRANSISTOR 2SC3311A-QRS					
Q121	8-729-423-37	TRANSISTOR 2SC3311A-QRS					
Q122	8-729-423-37	TRANSISTOR 2SC3311A-QRS					
Q123	8-729-423-44	TRANSISTOR 2SA1309A-QRS					
Q301	8-729-423-35	TRANSISTOR 2SC3311A-R					
Q302	8-729-423-35	TRANSISTOR 2SC3311A-R					
Q303	8-729-423-37	TRANSISTOR 2SC3311A-QRS					
Q304	8-729-423-37	TRANSISTOR 2SC3311A-QRS					
Q305	8-729-423-44	TRANSISTOR 2SA1309A-QRS					
Q306	8-729-423-37	TRANSISTOR 2SC3311A-QRS					
Q354	8-729-423-44	TRANSISTOR 2SA1309A-QRS					
Q371	8-729-423-37	TRANSISTOR 2SC3311A-QRS					
Q398	8-729-423-37	TRANSISTOR 2SC3311A-QRS					
Q401	8-729-423-37	TRANSISTOR 2SC3311A-QRS					
Q501 $\Delta$	8-729-202-03	TRANSISTOR 2SD1408-Y					
Q502	8-729-423-44	TRANSISTOR 2SA1309A-QRS					
Q503	8-729-423-37	TRANSISTOR 2SC3311A-QRS					
Q504	8-729-423-44	TRANSISTOR 2SA1309A-QRS					
Q505	8-729-423-37	TRANSISTOR 2SC3311A-QRS					
Q506	8-729-423-44	TRANSISTOR 2SA1309A-QRS					
Q507	8-729-423-37	TRANSISTOR 2SC3311A-QRS					
Q550	8-729-119-80	TRANSISTOR 2SC2688-LK					
Q551	8-729-821-87	TRANSISTOR 2SD1878-CA					
Q552	8-729-423-37	TRANSISTOR 2SC3311A-QRS					
Q553	8-729-200-17	TRANSISTOR 2SA1091-0					
Q599	8-729-378-84	TRANSISTOR 2SD788-5					
Q601	8-729-255-12	TRANSISTOR 2SC2551-0					

The components identified by shading and mark  $\Delta$  are critical for safety. Replace only with part number specified.

Les composants identifiés par une trame et une marque  $\Delta$  sont critiques pour la sécurité. Ne les remplacer que par une pièce portant le numéro spécifié.

The components identified by  $\boxtimes$  in this manual have been carefully factory-selected for each set in order to satisfy regulations regarding X-ray radiation. Should replacement be required, replace only with the value originally used.

A

REF. NO.	PART NO.	DESCRIPTION	REMARK	REF. NO.	PART NO.	DESCRIPTION	REMARK
<RESISTOR>							
R001	1-249-421-11	CARBON	2.2K 5% 1/4W	R139	1-249-433-11	CARBON	22K 5% 1/4W
R002	1-249-414-11	CARBON	560 5% 1/4W	R142	1-249-429-11	CARBON	10K 5% 1/4W
R003	1-249-414-11	CARBON	560 5% 1/4W	R143	1-249-429-11	CARBON	10K 5% 1/4W
R004	1-249-414-11	CARBON	560 5% 1/4W	R146	1-249-417-11	CARBON	1K 5% 1/4W
R005	1-249-414-11	CARBON	560 5% 1/4W	R147	1-249-428-11	CARBON	8.2K 5% 1/4W
R008	1-249-414-11	CARBON	560 5% 1/4W	R148	1-249-432-11	CARBON	18K 5% 1/4W
R010	1-249-417-11	CARBON	1K 5% 1/4W	R149	1-249-423-11	CARBON	3.3K 5% 1/4W
R011	1-249-417-11	CARBON	1K 5% 1/4W	R150	1-249-437-11	CARBON	47K 5% 1/4W
R013	1-249-414-11	CARBON	560 5% 1/4W	R151	1-249-429-11	CARBON	10K 5% 1/4W
R014	1-249-421-11	CARBON	2.2K 5% 1/4W	R152	1-249-440-11	CARBON	82K 5% 1/4W
R015	1-249-421-11	CARBON	2.2K 5% 1/4W	R153	1-247-903-00	CARBON	1M 5% 1/4W
R016	1-249-421-11	CARBON	2.2K 5% 1/4W	R157	1-249-405-11	CARBON	100 5% 1/4W
R017	1-249-421-11	CARBON	2.2K 5% 1/4W	R159	1-249-405-11	CARBON	100 5% 1/4W
R018	1-249-416-11	CARBON	820 5% 1/4W	R170	1-249-415-11	CARBON	680 5% 1/4W
R019	1-249-429-11	CARBON	10K 5% 1/4W	R172	1-249-429-11	CARBON	10K 5% 1/4W
R020	1-249-429-11	CARBON	10K 5% 1/4W	R174	1-249-437-11	CARBON	47K 5% 1/4W
R021	1-249-434-11	CARBON	27K 5% 1/4W	R175	1-249-441-11	CARBON	100K 5% 1/4W
R022	1-249-414-11	CARBON	560 5% 1/4W	R176	1-249-441-11	CARBON	100K 5% 1/4W
R023	1-249-414-11	CARBON	560 5% 1/4W	R180	1-249-426-11	CARBON	5.6K 5% 1/4W
R024	1-249-421-11	CARBON	2.2K 5% 1/4W	R182	1-249-415-11	CARBON	680 5% 1/4W
R025	1-249-421-11	CARBON	2.2K 5% 1/4W	R185	1-249-429-11	CARBON	10K 5% 1/4W
R026	1-249-421-11	CARBON	2.2K 5% 1/4W	R203	1-247-885-00	CARBON	180K 5% 1/4W
R027	1-249-421-11	CARBON	2.2K 5% 1/4W	R204	1-249-434-11	CARBON	27K 5% 1/4W
R028	1-249-423-11	CARBON	3.3K 5% 1/4W	R206	1-249-417-11	CARBON	1K 5% 1/4W
R029	1-249-414-11	CARBON	560 5% 1/4W	R207	1-249-435-11	CARBON	33K 5% 1/4W
R030	1-249-405-11	CARBON	100 5% 1/4W	R208	1-249-425-11	CARBON	4.7K 5% 1/4W
R031	1-249-414-11	CARBON	560 5% 1/4W	R217	1-249-417-11	CARBON	1K 5% 1/4W
R032	1-249-414-11	CARBON	560 5% 1/4W	R229	1-249-429-11	CARBON	10K 5% 1/4W
R035	1-249-417-11	CARBON	1K 5% 1/4W	R251	1-249-434-11	CARBON	27K 5% 1/4W
R036	1-249-416-11	CARBON	820 5% 1/4W	R252	$\Delta$ 1-249-401-91	CARBON	47 5% 1/4W F
R037	1-249-416-11	CARBON	820 5% 1/4W	R253	1-249-409-11	CARBON	220 5% 1/4W F
R038	1-249-414-11	CARBON	560 5% 1/4W	R254	1-249-409-11	CARBON	10K 5% 1/4W
R040	1-249-431-11	CARBON	15K 5% 1/4W	R261	1-249-434-11	CARBON	27K 5% 1/4W
R044	1-249-414-11	CARBON	560 5% 1/4W	R262	$\Delta$ 1-249-401-91	CARBON	47 5% 1/4W F
R046	1-249-433-11	CARBON	22K 5% 1/4W	R264	1-249-413-11	CARBON	470 5% 1/4W F
R047	1-249-439-11	CARBON	68K 5% 1/4W	R265	1-249-431-11	CARBON	15K 5% 1/4W
R089	1-249-405-11	CARBON	100 5% 1/4W	R301	1-215-472-00	METAL	130K 1% 1/6W
R090	1-249-405-11	CARBON	100 5% 1/4W	R302	1-249-438-11	CARBON	56K 5% 1/4W
R102	1-249-417-11	CARBON	1K 5% 1/4W	R304	1-247-889-00	CARBON	270K 5% 1/4W
R103	1-215-923-00	METAL OXIDE	10K 5% 3W F	R305	1-249-440-11	CARBON	82K 5% 1/4W
R108	1-249-425-11	CARBON	4.7K 5% 1/4W	R306	1-249-437-11	CARBON	47K 5% 1/4W
R113	1-249-417-11	CARBON	1K 5% 1/4W	R307	1-249-429-11	CARBON	10K 5% 1/4W
R115	1-249-417-11	CARBON	1K 5% 1/4W	R308	1-249-411-11	CARBON	330 5% 1/4W
R116	1-249-421-11	CARBON	2.2K 5% 1/4W	R309	1-249-411-11	CARBON	330 5% 1/4W
R117	1-249-421-11	CARBON	2.2K 5% 1/4W	R310	1-249-411-11	CARBON	330 5% 1/4W
R118	1-249-433-11	CARBON	22K 5% 1/4W	R312	1-249-405-11	CARBON	100 5% 1/4W
R120	1-249-437-11	CARBON	47K 5% 1/4W	R313	1-249-427-11	CARBON	6.8K 5% 1/4W
R121	1-249-434-11	CARBON	27K 5% 1/4W	R314	1-249-407-11	CARBON	150 5% 1/4W
R123	1-249-417-11	CARBON	1K 5% 1/4W	R315	1-249-417-11	CARBON	1K 5% 1/4W
R124	1-249-417-11	CARBON	1K 5% 1/4W	R316	1-249-411-11	CARBON	330 5% 1/4W
R125	1-249-417-11	CARBON	1K 5% 1/4W	R317	1-249-419-11	CARBON	1.5K 5% 1/4W
R126	1-249-429-11	CARBON	10K 5% 1/4W	R318	1-249-417-11	CARBON	1K 5% 1/4W
R127	1-249-413-11	CARBON	470 5% 1/4W	R319	1-249-417-11	CARBON	1K 5% 1/4W
R129	1-249-423-11	CARBON	3.3K 5% 1/4W	R320	1-249-417-11	CARBON	1K 5% 1/4W
R132	1-249-429-11	CARBON	10K 5% 1/4W	R321	1-249-433-11	CARBON	22K 5% 1/4W
R133	1-249-433-11	CARBON	22K 5% 1/4W	$\boxtimes$ R322 $\Delta$		CARBON	
R134	1-249-405-11	CARBON	100 5% 1/4W	R323	1-249-427-11	CARBON	6.8K 5% 1/4W
R135	1-249-438-11	CARBON	56K 5% 1/4W	$\boxtimes$ R324 $\Delta$		CARBON	
R136	1-249-405-11	CARBON	100 5% 1/4W	R325	$\Delta$ 1-249-389-11	CARBON	4.7 5% 1/4W F
R138	1-249-411-11	CARBON	330 5% 1/4W	R326	1-249-441-11	CARBON	100K 5% 1/4W
				R328	1-249-419-11	CARBON	1.5K 5% 1/4W
				R329	1-249-441-11	CARBON	100K 5% 1/4W
				R330	1-249-426-11	CARBON	5.6K 5% 1/4W
				R331	1-249-417-11	CARBON	1K 5% 1/4W

**A**

The components identified by shading and mark **Δ** are critical for safety. Replace only with part number specified.

Les composants identifiés par une trame et une marque **Δ** sont critiques pour la sécurité. Ne les remplacer que par une pièce portant le numéro spécifié.

REF. NO.	PART NO.	DESCRIPTION	REMARK	REF. NO.	PART NO.	DESCRIPTION	REMARK
R333	1-249-429-11	CARBON		R461	Δ1-202-726-91	SOLID	
R334	1-249-413-11	CARBON				3.9M 10%	1/2W
R335	1-249-425-11	CARBON		R501	1-216-458-11	METAL OXIDE	1.8K 5%
R336	1-249-441-11	CARBON		R502	1-216-458-11	METAL OXIDE	1.8K 5%
R337	1-249-417-11	CARBON		R503	1-216-458-11	METAL OXIDE	1.8K 5%
				R504	1-216-458-11	METAL OXIDE	1.8K 5%
				R505	1-215-472-00	METAL	130K 1%
R338	1-247-903-00	CARBON				150 5%	1/4W
R341	1-249-417-11	CARBON		R506	1-249-407-11	CARBON	5.6K 5%
R342	1-249-421-11	CARBON		R507	1-249-426-11	CARBON	47K 5%
R350	1-249-437-11	CARBON		R508	1-249-437-11	CARBON	27K 5%
R352	1-247-889-00	CARBON		R509	1-249-434-11	CARBON	2.7K 5%
				R510	1-249-422-11	CARBON	2.7K 5%
R353	1-249-429-11	CARBON				18 5%	3W
R354	1-249-405-11	CARBON		R511	Δ1-216-470-00	METAL OXIDE	330 5%
R355	1-249-433-11	CARBON		R512	1-249-411-11	CARBON	130K 1%
R357	1-249-405-11	CARBON		R513	1-215-472-00	METAL	33K 1%
R360	1-249-426-11	CARBON		R514	1-215-457-00	METAL	6.8K 5%
				R515	1-249-427-11	CARBON	
R361	1-249-429-11	CARBON				8.2K 5%	1/4W
R362	1-215-883-11	METAL OXIDE		R516	1-249-428-11	CARBON	1K 5%
R363	1-249-422-11	CARBON		R517	1-249-417-11	CARBON	6.8 5%
R364	1-249-420-11	CARBON		R518	Δ1-216-379-91	METAL OXIDE	3.9K 5%
R366	1-249-430-11	CARBON		R519	1-249-424-11	CARBON	2.2K 5%
				R520	1-249-421-11	CARBON	
R367	1-249-436-11	CARBON				1K 5%	1/4W
R368	1-249-427-11	CARBON		R521	1-249-417-11	CARBON	15K 5%
R371	1-249-429-11	CARBON		R522	1-249-431-11	CARBON	1K 5%
R379	1-249-434-11	CARBON		R523	1-249-417-11	CARBON	10K 5%
R398	1-249-423-11	CARBON		R524	1-249-429-11	CARBON	1K 5%
				R525	1-249-417-11	CARBON	1K 5%
R401	1-249-409-11	CARBON				3.3K 5%	1/4W
R402	1-249-438-11	CARBON		R526	1-249-423-11	CARBON	6.8M 5%
R403	1-249-438-11	CARBON		R527	1-259-871-15	CARBON	1.5K 5%
R404	1-249-437-11	CARBON		R528	1-249-419-11	CARBON	1K 5%
R405	1-249-438-11	CARBON		R529	1-249-417-11	CARBON	1K 5%
				R530	1-249-433-11	CARBON	22K 5%
R406	1-249-405-11	CARBON				270 5%	1/4W
R408	1-249-438-11	CARBON		R531	1-249-410-11	CARBON	56K 5%
R409	1-249-441-11	CARBON		R532	1-249-438-11	CARBON	220K 5%
R410	1-249-438-11	CARBON		R533	1-247-887-00	CARBON	1K 5%
R411	1-249-405-11	CARBON		R534	1-249-417-11	CARBON	15K 5%
				R535	1-249-431-11	CARBON	
R412	1-249-441-11	CARBON				5.6K 5%	1/4W
R413	1-249-441-11	CARBON		R536	1-249-426-11	CARBON	12K 5%
R414	1-249-438-11	CARBON		R537	1-249-430-11	CARBON	100 5%
R415	1-249-438-11	CARBON		R538	1-249-405-11	CARBON	10 1%
R416	1-249-438-11	CARBON		R539	1-215-373-31	METAL	180 5%
				R540	1-249-408-11	CARBON	
R417	1-249-438-11	CARBON				6.8K 5%	1/4W
R418	1-249-405-11	CARBON		R541	1-249-427-11	CARBON	3.3K 5%
R419	1-249-405-11	CARBON		R542	1-249-423-11	CARBON	12K 5%
R420	1-249-434-11	CARBON		R543	1-249-430-11	CARBON	4.7K 5%
R421	1-249-405-11	CARBON		R544	1-249-425-11	CARBON	680 5%
				R545	1-247-750-11	CARBON	
R422	1-249-429-11	CARBON				1K 5%	1/4W
R423	1-249-429-11	CARBON		R546	1-249-417-11	CARBON	10K 5%
R424	1-249-429-11	CARBON		R547	1-249-429-11	CARBON	100K 5%
R426	1-249-424-11	CARBON		R548	1-249-496-11	CARBON	680 5%
R427	1-249-435-11	CARBON		R549	1-249-415-11	CARBON	15K 5%
				R550	1-249-431-11	CARBON	
R429	1-249-435-11	CARBON				15K 5%	1/4W
R430	1-249-424-11	CARBON		R551	1-249-431-11	CARBON	560 5%
R431	1-249-431-11	CARBON		R552	1-249-414-11	CARBON	6.8K 5%
R432	1-249-431-11	CARBON		R553	1-249-427-11	CARBON	470 5%
R433	1-249-409-11	CARBON		R554	1-249-413-11	CARBON	1.8 5%
				R555	1-216-352-11	METAL OXIDE	
R451	1-249-404-00	CARBON				1.5K 5%	1/4W
R452	1-249-438-11	CARBON		R556	1-249-419-11	CARBON	270 5%
R453	1-249-437-11	CARBON		R557	1-249-410-11	CARBON	680 5%
R454	1-249-438-11	CARBON		R558	1-249-415-11	CARBON	3.3K 5%
R455	1-249-437-11	CARBON		R559	1-249-423-11	CARBON	100K 5%
				R560	1-249-496-11	CARBON	
R456	1-249-441-11	CARBON				10K 5%	1/4W
R457	1-249-417-11	CARBON		R561	1-249-496-11	CARBON	39K 5%
R458	1-249-441-11	CARBON				10K 5%	1/4W
R459	1-249-417-11	CARBON		R562	1-249-429-11	CARBON	10K 5%
				R563	1-249-436-11	CARBON	39K 5%

The components identified by shading and mark  $\Delta$  are critical for safety. Replace only with part number specified.

Les composants identifiés par une trame et une marque  $\Delta$  sont critiques pour la sécurité. Ne les remplacer que par une pièce portant le numéro spécifié.



REF. NO.	PART NO.	DESCRIPTION	REMARK	REF. NO.	PART NO.	DESCRIPTION	REMARK
R564	1-215-417-00	METAL	680 1%	1/6W			
R565	1-249-425-11	CARBON	4.7K 5%	1/4W			
R566	1-247-883-00	CARBON	150K 5%	1/4W			
R567	1-216-380-11	METAL OXIDE	8.2 5%	2W			
R568	$\Delta$ 1-216-390-11	METAL OXIDE	1.2 5%	3W			
<SPARK GAP>							
SG501	1-519-422-11	GAP, SPARK					
<TRANSFORMER>							
R569	1-214-913-00	METAL	100K 1%	1/2W			
R570	1-215-898-11	METAL OXIDE	10K 5%	2W			
R571	1-216-356-00	METAL OXIDE	3.9 5%	1W			
R572	1-249-423-11	CARBON	3.3K 5%	1/4W			
R575	1-249-401-11	CARBON	47 5%	1/4W			
T251	$\Delta$ 1-427-479-11	TRANSFORMER (SOT)					
T261	$\Delta$ 1-427-479-11	TRANSFORMER (SOT)					
T501	1-437-195-11	TRANSFORMER, HORIZONTAL DRIVE					
T504	$\Delta$ 1-439-416-41	TRANSFORMER ASSY, FLYBACK (NX-1604)					
T599	$\Delta$ 1-421-857-11	TRANSFORMER, FERRITE					
T601	$\Delta$ 1-424-335-21	TRANSFORMER, LINE FILTER					
<THERMISTOR>							
THP601	$\Delta$ 1-808-081-14	THERMISTOR, POSITIVE					
<TUNER>							
TUI01	$\Delta$ 1-465-371-11	TUNER, ET (BTP-RA401) (KV-20TS27(U) ONLY)					
	$\Delta$ 1-465-371-21	TUNER, ET (BTP-RA401) (KV-20TS27(C) ONLY)					
<CRYSTAL>							
X101	1-577-082-11	VIBRATOR, CERAMIC					
X301	1-567-505-11	OSCILLATOR, CRYSTAL					
*****							
	*A-1296-821-A	A BOARD, COMPLETE (KV-20TR22(U) ONLY)					
*****							
	*1-508-765-00	PIN, CONNECTOR (5MM PITCH) 3P					
	*1-508-766-00	PIN, CONNECTOR (5MM PITCH) 4P					
	*1-508-767-00	PIN, CONNECTOR (5MM PITCH) 5P					
	*1-508-768-00	PIN, CONNECTOR (5MM PITCH) 6P					
	*1-508-786-00	PIN, CONNECTOR (5MM PITCH) 2P					
	1-533-223-11	CLIP, FUSE					
	*1-559-991-21	CONNECTOR ASSY 1P					
	*1-560-123-00	PLUG, CONNECTOR (2.5MM) 3P					
	*1-564-505-11	PLUG, CONNECTOR 2P					
	*1-564-509-11	PLUG, CONNECTOR 6P					
	*1-568-536-11	PLUG (MINIATURE DY) 6P					
	*1-580-843-11	PIN, CONNECTOR (POWER)					
	*4-341-751-01	EYELET (EY1, EY2, EY5, EY6, EY7, EY8, EY9, EY10, EY11, EY12, EY85, EY86, EY87, EY88, EY93, EY94, EY95, EY96, EY97, EY98, EY99, EY113,					
		EY114)					
	*4-341-752-01	EYELET (EY50, EY51, EY52, EY53, EY55, EY56, EY57, EY58, EY59, EY60, EY61, EY62, EY63, EY65, EY66, EY67, EY68, EY69, EY91, EY92, EY100, EY101, EY102, EY103, EY104, EY105, EY106,					
		EY107, EY108, EY109, EY110, EY111)					
	*4-363-404-00	HOLDER, IC					
	4-369-267-01	SPACER, MICA					
<VARIABLE RESISTOR>							
RV131	1-238-012-11	RES, ADJ, CARBON 1K					
RV201	1-238-016-11	RES, ADJ, CARBON 10K					
RV299	1-238-011-11	RES, ADJ, CARBON 470					
RV306	1-238-016-11	RES, ADJ, CARBON 10K					
RV307	1-238-011-11	RES, ADJ, CARBON 470					
RV501	1-228-728-00	RES, ADJ, CERAMIC CARBON 100K					
RV502	1-238-020-11	RES, ADJ, CARBON 100K					
RV503	1-224-251-99	RES, ADJ, METAL GLAZE 4.7K					
RV505	1-238-017-11	RES, ADJ, CARBON 22K					
RV506	1-238-019-11	RES, ADJ, CARBON 47K					
RV507	1-238-010-11	RES, ADJ, CARBON 330					
RV508	1-238-012-11	RES, ADJ, CARBON 1K					
<RELAY>							
RY601	$\Delta$ 1-515-573-13	RELAY, POWER					
<SWITCH>							
S101	$\Delta$ 1-571-532-23	SWITCH, TACTIL (POWER)					
S102	1-571-532-21	SWITCH, TACTIL					
S103	1-571-532-21	SWITCH, TACTIL					
S104	1-571-532-21	SWITCH, TACTIL					
S105	1-571-532-21	SWITCH, TACTIL					
S106	1-571-532-21	SWITCH, TACTIL					
S401	1-554-706-11	SWITCH, SLIDE					
<CAPACITOR>							
C047	1-124-927-11	ELECT	4.7MF	20%	50 V		
C101	1-164-077-11	CERAMIC	220PF	10%	50 V		
C102	1-126-233-11	ELECT	22MF	20%	50 V		
C103	1-126-103-11	ELECT	470MF	20%	16 V		
C104	1-126-101-11	ELECT	100MF	20%	16 V		

A

Les composants identifiés par une trame et une marque  $\Delta$  sont critiques pour la sécurité. Ne les remplacer que par une pièce portant le numéro spécifique.

The components identified by shading and mark  $\Delta$  are critical for safety. Replace only with part number specified.

REF. NO.	PART NO.	DESCRIPTION	REMARK	REF. NO.	PART NO.	DESCRIPTION	REMARK
C105	1-164-077-11	CERAMIC	220PF 10%	50V	C508	1-101-006-00	CERAMIC 0.047MF 50V
C107	1-101-361-00	CERAMIC	150PF 5%	50V	C509	1-101-006-00	CERAMIC 0.047MF 50V
C108	1-101-361-00	CERAMIC	150PF 5%	50V	C510	1-106-367-00	MYLAR 0.01MF 10%
C109	1-124-927-11	ELECT	4.7MF 20%	50V	C511	1-106-379-12	MYLAR 0.033MF 10%
C110	1-124-927-11	ELECT	4.7MF 20%	50V	C512	1-124-925-11	ELECT 2.2MF 20%
C114	1-124-907-11	ELECT	10MF 20%	50V	C513	1-124-903-11	ELECT 1MF 20%
C115	1-126-103-11	ELECT	470MF 20%	16V	C514	1-124-907-11	ELECT 10MF 20%
C116	1-136-165-00	FILM	0.1MF 5%	50V	C515	1-124-464-11	ELECT 0.22MF 20%
C118	1-106-367-00	MYLAR	0.01MF 10%	100V	C516	1-124-477-11	ELECT 47MF 20%
C120	1-106-383-00	MYLAR	0.047MF 200V		C517	$\Delta$ 1-108-427-91	MYLAR 0.033MF 10%
C121	1-124-477-11	ELECT	47MF 20%	16V	C518	1-102-125-00	CERAMIC 0.0047MF 10%
C126	1-124-902-00	ELECT	0.47MF 20%	50V	C520	1-106-385-00	MYLAR 0.056MF 10%
C132	1-164-033-11	CERAMIC	39PF 5%	50V	C521	1-124-903-11	ELECT 1MF 20%
C133	1-102-973-00	CERAMIC	100PF 5%	50V	C522	1-102-824-00	CERAMIC 470PF 5%
C135	1-102-121-00	CERAMIC	0.0022MF 10%	50V	C523	1-124-927-11	ELECT 4.7MF 20%
C139	1-124-477-11	ELECT	47MF 20%	16V	C530	1-124-277-11	ELECT 4.7MF 20%
C140	1-102-121-00	CERAMIC	0.0022MF 10%	50V	C534	1-124-122-11	ELECT 100MF 20%
C142	1-101-005-00	CERAMIC	0.022MF 50V		C535	1-102-030-00	CERAMIC 330PF 10%
C143	1-106-379-12	MYLAR	0.033MF 10%	100V	C537	1-106-363-00	MYLAR 0.0068MF 10%
C144	1-106-375-12	MYLAR	0.022MF 10%	100V	C538	1-106-375-12	MYLAR 0.022MF 10%
C201	1-126-101-11	ELECT	100MF 20%	16V	C539	1-124-927-11	ELECT 4.7MF 20%
C205	1-124-907-11	ELECT	10MF 20%	50V	C540	1-124-925-11	ELECT 2.2MF 20%
C206	1-102-125-00	CERAMIC	0.0047MF 10%	50V	C541	1-124-910-11	ELECT 47MF 20%
C261	1-124-925-11	ELECT	2.2MF 20%	100V	C542	1-123-587-00	ELECT 560MF 10%
C262	1-124-799-11	ELECT	2.2MF 20%	160V	C543	1-124-907-11	ELECT 10MF 20%
C263	1-124-667-11	ELECT	10MF 20%	100V	C544	1-124-925-11	ELECT 2.2MF 20%
C265	1-124-910-11	ELECT	47MF 20%	50V	C546	1-106-343-00	MYLAR 0.001MF 10%
C266	1-106-379-12	MYLAR	0.033MF 10%	100V	C548	1-102-212-00	CERAMIC 820PF 10%
C301	1-124-902-00	ELECT	0.47MF 20%	50V	C549	1-124-913-11	ELECT 470MF 20%
C302	1-164-056-11	CERAMIC	27PF 5%	50V	C550	1-124-902-00	ELECT 0.47MF 20%
C303	1-126-101-11	ELECT	100MF 20%	16V	C551	1-164-081-11	CERAMIC 470PF 10%
C305	1-124-902-00	ELECT	0.47MF 20%	50V	C552	$\Delta$ 1-162-115-91	CERAMIC 330PF 10%
C309	1-124-903-11	ELECT	1MF 20%	50V	C553	1-102-228-00	CERAMIC 470PF 10%
C312	1-164-050-11	CERAMIC	15PF 5%	50V	C554	1-162-116-00	CERAMIC 680PF 10%
C314	1-164-070-11	CERAMIC	100PF 5%	50V	C555	1-106-367-00	MYLAR 0.01MF 10%
C315	1-124-907-11	ELECT	10MF 20%	50V	C556	1-126-101-11	ELECT 100MF 20%
C317	1-126-233-11	ELECT	22MF 20%	50V	C557	1-123-024-21	ELECT 33MF 160V
C318	1-102-074-00	CERAMIC	0.001MF 10%	50V	C558	1-124-046-00	ELECT 10MF 20%
C321	1-102-129-00	CERAMIC	0.01MF 10%	50V	C559	1-106-391-12	MYLAR 0.1MF 10%
C322	1-124-907-11	ELECT	10MF 20%	50V	C560	1-136-109-00	FILM 0.68MF 5%
C330	1-124-120-11	ELECT	220MF 20%	16V	C561	1-124-634-11	ELECT 1MF 20%
C331	1-126-101-11	ELECT	100MF 20%	16V	C562	$\Delta$ 1-102-228-91	CERAMIC 470PF 10%
C340	1-123-932-00	ELECT	4.7MF 20%	160V	C563	$\Delta$ 1-137-231-11	FILM 0.015MF 3%
C342	1-102-074-00	CERAMIC	0.001MF 10%	50V	C564	$\Delta$ 1-136-111-11	FILM 1MF 5%
C351	1-124-477-11	ELECT	47MF 20%	16V	C565	$\Delta$ 1-136-313-51	FILM 0.047MF 5%
C352	1-124-477-11	ELECT	47MF 20%	16V	C566	1-126-163-11	ELECT 4.7MF 20%
C353	1-124-907-11	ELECT	10MF 20%	50V	C567	1-162-318-11	CERAMIC 0.001MF 10%
C356	1-124-477-11	ELECT	47MF 20%	16V	C568	1-106-383-00	MYLAR 0.047MF 10%
C364	1-124-480-11	ELECT	470MF 20%	25V	C569	1-106-375-12	MYLAR 0.022MF 20V
C366	1-124-907-11	ELECT	10MF 20%	50V	C570	1-162-114-00	CERAMIC 0.0047MF 2V
C367	1-124-477-11	ELECT	47MF 20%	16V	C571	1-106-371-00	MYLAR 0.015MF 20V
C398	1-164-077-11	CERAMIC	220PF 10%	50V	C572	1-124-907-11	ELECT 10MF 20%
C402	1-124-119-00	ELECT	330MF 20%	16V	C575	1-106-359-00	MYLAR 0.0047MF 10%
C403	1-124-907-11	ELECT	10MF 20%	50V	C579	1-129-898-00	FILM 0.0022MF 5%
C408	1-124-907-11	ELECT	10MF 20%	50V	C580	1-162-116-00	CERAMIC 680PF 10%
C421	1-124-907-11	ELECT	10MF 20%	50V	C594	1-124-557-11	ELECT 1000MF 20%
C451	1-124-119-00	ELECT	330MF 20%	16V	C595	1-102-212-00	CERAMIC 820PF 10%
C452	1-124-903-11	ELECT	1MF 20%	50V	C596	1-162-117-00	CERAMIC 100PF 10%
C461	$\Delta$ 1-161-742-51	CERAMIC	0.0022MF 20%	400V	C597	1-124-484-11	ELECT 220MF 20%
C501	1-126-101-11	ELECT	100MF 20%	16V	C599	1-124-120-11	ELECT 220MF 20%
C502	1-106-363-00	MYLAR	0.0068MF 10%	100V	C601	$\Delta$ 1-108-745-52	MYLAR 0.22MF 20%
C503	1-124-903-11	ELECT	1MF 20%	50V	C602	1-125-679-31	ELECT 560MF 20%
C505	1-106-363-00	MYLAR	0.0068MF 10%	100V	C603	1-161-830-00	CERAMIC 0.0047MF 50V
C507	1-164-077-11	CERAMIC	220PF 10%	50V			



The components identified by shading and mark  $\Delta$  are critical for safety. Replace only with part number specified.

Les composants identifiés par une trame et une marque  $\Delta$  sont critiques pour la sécurité. Ne les remplacer que par une pièce portant le numéro spécifié.

KV-20TR22/20TS27  
RM-781 RM-783

A

REF. NO.	PART NO.	DESCRIPTION	REMARK	REF. NO.	PART NO.	DESCRIPTION	REMARK
C604	1-161-830-00	CERAMIC	0.0047MF	500V	D606	8-719-911-55	DIODE U05G
C605	1-123-948-00	ELECT	22MF	20%			
C606	1-126-176-11	ELECT	220MF	20%			
C615	1-124-046-00	ELECT	10MF	20%			
C616	1-124-046-00	ELECT	10MF	20%			
C617	1-124-046-00	ELECT	10MF	20%			
<FILTER>				<FUSE>			
CF301	1-409-344-00	CERAMIC TRAP	3.58MHZ	F601 $\Delta$	1-532-748-11	FUSE, GLASS TUBE 6.3A/125V	
<COMPOSITION CIRCUIT BLOCK>				F602 $\Delta$	1-532-741-11	FUSE, GLASS TUBE 1.25A/125V	
CP008	1-233-147-11	COMPOSITION CIRCUIT BLOCK		<IC>			
CP102	1-233-145-11	COMPOSITION CIRCUIT BLOCK		IC101	8-759-636-45	IC M34302M8-514SP	
CP104	1-233-147-11	COMPOSITION CIRCUIT BLOCK		IC102	8-759-748-69	IC CAT59C11HP	
CP106	1-236-357-11	NETWORK, RES		IC103	8-741-618-11	IC SBX1618-11	
CP107	1-233-146-11	COMPOSITION CIRCUIT BLOCK		IC261 $\Delta$	8-749-900-15	IC SI-4102	
CP108	1-233-118-11	COMPOSITION CIRCUIT BLOCK		IC301	8-752-031-72	IC CXA1013AS	
CP109	1-233-117-11	COMPOSITION CIRCUIT BLOCK		IC302	8-759-800-81	IC LA7016	
CP112	1-236-490-11	NETWORK, RES, THICK FILM		IC303	8-759-104-05	IC UPD6325C	
CP117	1-236-078-11	NETWORK, RES, THICK FILM		IC304	8-759-231-56	IC TA7809S	
CP351	1-236-253-11	NETWORK, RES, THICK FILM		IC305	8-759-929-62	IC LM7812CT	
<DIODE>				IC401	1-809-366-11	INSULATING MODULE, VIDEO	
D001	8-719-911-19	DIODE	1SS119	IC402	1-809-365-11	INSULATING MODULE, AUDIO	
D081	8-719-911-19	DIODE	1SS119	IC406	8-759-932-33	IC BU4066B	
D082	8-719-109-86	DIODE	RD5.1ES-B3	IC501	8-759-105-82	IC UPC1378H-P	
D101	8-719-110-78	DIODE	RD33ES-B2	IC502	8-759-945-58	IC RC4558P	
D104	1-809-401-21	LED UNIT		IC601 $\Delta$	8-749-930-35	IC STR3035	
D113	8-719-911-19	DIODE	1SS119	<IF BLOCK>			
D114	8-719-911-19	DIODE	1SS119	IF201	1-464-756-21	IF BLOCK (IFF-450A)	
D115	8-719-109-74	DIODE	RD4.3ES-B1	<JACK>			
D117	8-719-109-89	DIODE	RD5.6ES-B2	J451	1-569-354-11	JACK BLOCK, PIN 2P	
D118	8-719-911-19	DIODE	1SS119	<COIL>			
D119	8-719-911-19	DIODE	1SS119	L102	1-408-421-00	INDUCTOR	100UH
D120	8-719-911-19	DIODE	1SS119	L103	1-408-421-00	INDUCTOR	100UH
D121	8-719-911-19	DIODE	1SS119	L104	1-408-404-00	INDUCTOR	3.9UH
D128	8-719-911-19	DIODE	1SS119	L108	1-408-411-00	INDUCTOR	15UH
D321	8-719-302-43	DIODE	EL1Z	L109	1-408-411-00	INDUCTOR	15UH
D350	8-719-911-19	DIODE	1SS119	L203	1-408-408-00	INDUCTOR	8.2UH
D351	8-719-911-19	DIODE	1SS119	L301	1-408-411-00	INDUCTOR	15UH
D451	8-719-911-19	DIODE	1SS119	L302	1-408-412-00	INDUCTOR	18UH
D452	8-719-911-19	DIODE	1SS119	L501	1-410-666-31	INDUCTOR	18UH
D501	8-719-109-89	DIODE	RD5.6ES-B2	L503	1-410-669-31	INDUCTOR	33UH
D508	8-719-911-55	DIODE	U05G	L505	1-459-104-00	COIL, DUST CORE	
D511	8-719-300-33	DIODE	RU-3AM	L506	1-407-365-00	COIL, CHOKE	
D512	8-719-911-19	DIODE	1SS119	L508	1-412-553-11	INDUCTOR	3.3MMH
D513	8-719-988-57	DIODE	BY228	L509 $\Delta$	1-459-390-31	COIL (WITH CORE)	
D514	8-719-988-55	DIODE	RGPI5K-6179	L510 $\Delta$	1-459-626-12	HLC	
D515	8-719-911-55	DIODE	U05G	L511	1-459-075-00	COIL, DYNAMIC CONVERSION CHOKE	
D516	8-719-911-55	DIODE	U05G	L513	1-410-665-31	INDUCTOR	15UH
D517	8-719-300-33	DIODE	RU-3AM	L516 $\Delta$	1-412-524-21	INDUCTOR	8.2UH
D518 $\Delta$	8-719-976-64	DIODE	RGPO2-17	L601 $\Delta$	1-412-519-21	INDUCTOR	3.3UH
D519 $\Delta$	8-719-976-64	DIODE	RGPO2-17	L602 $\Delta$	1-412-519-21	INDUCTOR	3.3UH
D597	8-719-979-85	DIODE	EGP20G	L609	1-408-398-00	INDUCTOR	1.2UH
D598	8-719-300-33	DIODE	RU-3AM	<MODULE>			
D599	8-719-110-35	DIODE	RD13ES-B1	PM501	1-809-335-11	MODULE, PROTECTOR (PM-22)	
D601 $\Delta$	8-719-305-07	DIODE	RBV-406H				
D602 $\Delta$	8-719-908-03	DIODE	GP08D				
D603	8-719-304-63	DIODE	RM11C				
D604	8-719-304-63	DIODE	RM11C				
D605	8-719-109-93	DIODE	RD6.2ES-B2				

A

REF. NO.	PART NO.	DESCRIPTION	REMARK	REF. NO.	PART NO.	DESCRIPTION	REMARK
<TRANSISTOR>				R031	1-249-414-11	CARBON	560 5% 1/4W
Q107	8-729-423-37	TRANSISTOR 2SC3311A-QRS		R035	1-249-417-11	CARBON	1K 5% 1/4W
Q109	8-729-423-44	TRANSISTOR 2SA1309A-QRS		R036	1-249-416-11	CARBON	820 5% 1/4W
Q110	8-729-423-37	TRANSISTOR 2SC3311A-QRS		R037	1-249-416-11	CARBON	820 5% 1/4W
Q112	8-729-378-84	TRANSISTOR 2SD788-5		R038	1-249-414-11	CARBON	560 5% 1/4W
Q113	8-729-423-44	TRANSISTOR 2SA1309A-QRS		R040	1-249-431-11	CARBON	15K 5% 1/4W
Q114	8-729-423-37	TRANSISTOR 2SC3311A-QRS		R044	1-249-414-11	CARBON	560 5% 1/4W
Q115	8-729-423-37	TRANSISTOR 2SC3311A-QRS		R046	1-249-433-11	CARBON	22K 5% 1/4W
Q116	8-729-423-37	TRANSISTOR 2SC3311A-QRS		R047	1-249-439-11	CARBON	68K 5% 1/4W
Q119	8-729-423-37	TRANSISTOR 2SC3311A-QRS		R089	1-249-405-11	CARBON	100 5% 1/4W
Q120	8-729-423-37	TRANSISTOR 2SC3311A-QRS		R090	1-249-405-11	CARBON	100 5% 1/4W
Q121	8-729-423-37	TRANSISTOR 2SC3311A-QRS		R102	1-249-417-11	CARBON	1K 5% 1/4W
Q122	8-729-423-37	TRANSISTOR 2SC3311A-QRS		R103	1-215-923-00	METAL OXIDE	10K 5% 3W F
Q123	8-729-423-44	TRANSISTOR 2SA1309A-QRS		R108	1-249-425-11	CARBON	4.7K 5% 1/4W
Q201	8-729-423-37	TRANSISTOR 2SC3311A-QRS		R113	1-249-417-11	CARBON	1K 5% 1/4W
Q301	8-729-423-35	TRANSISTOR 2SC3311A-R		R115	1-249-417-11	CARBON	1K 5% 1/4W
Q302	8-729-423-35	TRANSISTOR 2SC3311A-R		R116	1-249-421-11	CARBON	2.2K 5% 1/4W
Q303	8-729-423-37	TRANSISTOR 2SC3311A-QRS		R117	1-249-421-11	CARBON	2.2K 5% 1/4W
Q304	8-729-423-37	TRANSISTOR 2SC3311A-QRS		R118	1-249-433-11	CARBON	22K 5% 1/4W
Q305	8-729-423-44	TRANSISTOR 2SA1309A-QRS		R120	1-249-437-11	CARBON	47K 5% 1/4W
Q306	8-729-423-37	TRANSISTOR 2SC3311A-QRS		R121	1-249-434-11	CARBON	27K 5% 1/4W
Q354	8-729-423-44	TRANSISTOR 2SA1309A-QRS		R123	1-249-417-11	CARBON	1K 5% 1/4W
Q371	8-729-423-37	TRANSISTOR 2SC3311A-QRS		R124	1-249-417-11	CARBON	1K 5% 1/4W
Q398	8-729-423-37	TRANSISTOR 2SC3311A-QRS		R125	1-249-417-11	CARBON	1K 5% 1/4W
Q401	8-729-423-37	TRANSISTOR 2SC3311A-QRS		R126	1-249-429-11	CARBON	10K 5% 1/4W
Q501	8-729-202-03	TRANSISTOR 2SD1408-Y		R127	1-249-413-11	CARBON	470 5% 1/4W
Q502	8-729-423-44	TRANSISTOR 2SA1309A-QRS		R129	1-249-423-11	CARBON	3.3K 5% 1/4W
Q503	8-729-423-37	TRANSISTOR 2SC3311A-QRS		R130	1-249-423-11	CARBON	3.3K 5% 1/4W
Q504	8-729-423-44	TRANSISTOR 2SA1309A-QRS		R132	1-249-429-11	CARBON	10K 5% 1/4W
Q505	8-729-423-37	TRANSISTOR 2SC3311A-QRS		R133	1-249-433-11	CARBON	22K 5% 1/4W
Q506	8-729-423-44	TRANSISTOR 2SA1309A-QRS		R136	1-249-405-11	CARBON	100 5% 1/4W
Q507	8-729-423-37	TRANSISTOR 2SC3311A-QRS		R138	1-249-411-11	CARBON	330 5% 1/4W
Q550	8-729-119-80	TRANSISTOR 2SC2688-LK		R139	1-249-433-11	CARBON	22K 5% 1/4W
Q551	8-729-821-87	TRANSISTOR 2SD1878-CA		R142	1-249-429-11	CARBON	10K 5% 1/4W
Q552	8-729-423-37	TRANSISTOR 2SC3311A-QRS		R143	1-249-429-11	CARBON	10K 5% 1/4W
Q553	8-729-200-17	TRANSISTOR 2SA1091-0		R146	1-249-417-11	CARBON	1K 5% 1/4W
Q599	8-729-378-84	TRANSISTOR 2SD788-5		R147	1-249-428-11	CARBON	8.2K 5% 1/4W
Q601	8-729-255-12	TRANSISTOR 2SC2551-0		R148	1-249-432-11	CARBON	18K 5% 1/4W
<RESISTOR>				R149	1-249-423-11	CARBON	3.3K 5% 1/4W
R001	1-249-421-11	CARBON	2.2K 5% 1/4W	R150	1-249-437-11	CARBON	47K 5% 1/4W
R002	1-249-414-11	CARBON	560 5% 1/4W	R151	1-249-429-11	CARBON	10K 5% 1/4W
R003	1-249-414-11	CARBON	560 5% 1/4W	R152	1-249-440-11	CARBON	82K 5% 1/4W
R004	1-249-414-11	CARBON	560 5% 1/4W	R153	1-247-903-00	CARBON	1M 5% 1/4W
R005	1-249-414-11	CARBON	560 5% 1/4W	R157	1-249-405-11	CARBON	100 5% 1/4W
R008	1-249-414-11	CARBON	560 5% 1/4W	R159	1-249-405-11	CARBON	100 5% 1/4W
RO10	1-249-417-11	CARBON	1K 5% 1/4W	R170	1-249-415-11	CARBON	680 5% 1/4W
RO11	1-249-417-11	CARBON	1K 5% 1/4W	R172	1-249-429-11	CARBON	10K 5% 1/4W
RO13	1-249-414-11	CARBON	560 5% 1/4W	R174	1-249-437-11	CARBON	47K 5% 1/4W
RO14	1-249-421-11	CARBON	2.2K 5% 1/4W	R175	1-249-441-11	CARBON	100K 5% 1/4W
RO15	1-249-421-11	CARBON	2.2K 5% 1/4W	R176	1-249-441-11	CARBON	100K 5% 1/4W
RO16	1-249-421-11	CARBON	2.2K 5% 1/4W	R180	1-249-426-11	CARBON	5.6K 5% 1/4W
RO17	1-249-421-11	CARBON	2.2K 5% 1/4W	R182	1-249-415-11	CARBON	680 5% 1/4W
RO18	1-249-416-11	CARBON	820 5% 1/4W	R185	1-249-429-11	CARBON	10K 5% 1/4W
RO19	1-249-429-11	CARBON	10K 5% 1/4W	R203	1-247-885-00	CARBON	180K 5% 1/4W
RO20	1-249-429-11	CARBON	10K 5% 1/4W	R204	1-249-434-11	CARBON	27K 5% 1/4W
RO21	1-249-434-11	CARBON	27K 5% 1/4W	R205	1-249-417-11	CARBON	1K 5% 1/4W
RO22	1-249-414-11	CARBON	560 5% 1/4W	R206	1-249-417-11	CARBON	1K 5% 1/4W
RO23	1-249-414-11	CARBON	560 5% 1/4W	R207	1-249-435-11	CARBON	33K 5% 1/4W
RO26	1-249-421-11	CARBON	2.2K 5% 1/4W	R208	1-249-425-11	CARBON	4.7K 5% 1/4W
RO27	1-249-421-11	CARBON	2.2K 5% 1/4W	R209	1-249-417-11	CARBON	1K 5% 1/4W
RO28	1-249-423-11	CARBON	3.3K 5% 1/4W	R217	1-249-417-11	CARBON	1K 5% 1/4W
RO29	1-249-414-11	CARBON	560 5% 1/4W	R222	1-249-417-11	CARBON	1K 5% 1/4W
RO30	1-249-405-11	CARBON	100 5% 1/4W	R224	1-249-417-11	CARBON	1K 5% 1/4W

The components identified by shading and mark **△** are critical for safety. Replace only with part number specified.

Les composants identifiés par une trame et une marque **△** sont critiques pour la sécurité. Ne les remplacer que par une pièce portant le numéro spécifié.

\* The components identified by **☒** in this manual have been carefully factory-selected for each set in order to satisfy regulations regarding X-ray radiation. Should replacement be required, replace only with the value originally used.



REF. NO.	PART NO.	DESCRIPTION	REMARK	REF. NO.	PART NO.	DESCRIPTION	REMARK
R261	1-249-434-11	CARBON		R414	1-249-438-11	CARBON	
R262 <b>△</b>	1-249-401-91	CARBON		R415	1-249-438-11	CARBON	
R264	1-249-411-11	CARBON		R418	1-249-405-11	CARBON	
R265	1-249-430-11	CARBON		R420	1-249-434-11	CARBON	
R301	1-215-472-00	METAL		R421	1-249-405-11	CARBON	
R302	1-249-438-11	CARBON		R451	1-249-404-00	CARBON	
R304	1-247-889-00	CARBON		R452	1-247-885-00	CARBON	
R305	1-249-440-11	CARBON		R453	1-249-437-11	CARBON	
R306	1-249-437-11	CARBON		R461 <b>△</b>	1-202-726-91	SOLID	
R307	1-249-429-11	CARBON		R501	1-216-458-11	METAL OXIDE	
R308	1-249-411-11	CARBON		R502	1-216-458-11	METAL OXIDE	
R309	1-249-411-11	CARBON		R503	1-216-458-11	METAL OXIDE	
R310	1-249-411-11	CARBON		R504	1-216-458-11	METAL OXIDE	
R312	1-249-405-11	CARBON		R505	1-215-472-00	METAL	
R313	1-249-427-11	CARBON		R506	1-249-407-11	CARBON	
R314	1-249-407-11	CARBON		R507	1-249-426-11	CARBON	
R315	1-249-417-11	CARBON		R508	1-249-437-11	CARBON	
R316	1-249-411-11	CARBON		R509	1-249-434-11	CARBON	
R317	1-249-419-11	CARBON		R510	1-249-422-11	CARBON	
R318	1-249-417-11	CARBON		R511	1-216-470-00	METAL OXIDE	
R319	1-249-417-11	CARBON		R512	1-249-411-11	CARBON	
R320	1-249-417-11	CARBON		R513	1-215-472-00	METAL	
R321	1-249-433-11	CARBON		R514	1-215-457-00	METAL	
<b>☒</b> R322 <b>△</b>	1-249-427-11	CARBON		R515	1-249-427-11	CARBON	
R323	1-249-427-11	CARBON		R516	1-249-428-11	CARBON	
<b>☒</b> R324 <b>△</b>		CARBON		R517	1-249-417-11	CARBON	
R325	1-249-389-11	CARBON		R518 <b>△</b>	1-216-379-91	METAL OXIDE	
R326	1-249-441-11	CARBON		R519	1-249-424-11	CARBON	
R328	1-249-419-11	CARBON		R520	1-249-421-11	CARBON	
R329	1-249-441-11	CARBON		R521	1-249-417-11	CARBON	
R330	1-249-426-11	CARBON		R522	1-249-431-11	CARBON	
R331	1-249-417-11	CARBON		R523	1-249-417-11	CARBON	
R333	1-249-429-11	CARBON		R524	1-249-429-11	CARBON	
R334	1-249-413-11	CARBON		R525	1-249-417-11	CARBON	
R335	1-249-425-11	CARBON		R526	1-249-423-11	CARBON	
R336	1-249-441-11	CARBON		R527	1-259-871-15	CARBON	
R337	1-249-417-11	CARBON		R528	1-249-419-11	CARBON	
R338	1-247-903-00	CARBON		R529	1-249-417-11	CARBON	
R341	1-249-417-11	CARBON		R530	1-249-433-11	CARBON	
R342	1-249-421-11	CARBON		R531	1-249-410-11	CARBON	
R350	1-249-437-11	CARBON		R532	1-249-438-11	CARBON	
R352	1-247-889-00	CARBON		R533	1-247-887-00	CARBON	
R353	1-249-429-11	CARBON		R534	1-249-417-11	CARBON	
R354	1-249-405-11	CARBON		R535	1-249-431-11	CARBON	
R355	1-249-433-11	CARBON		R536	1-249-426-11	CARBON	
R357	1-249-405-11	CARBON		R537	1-249-430-11	CARBON	
R360	1-249-426-11	CARBON		R538	1-249-405-11	CARBON	
R361	1-249-429-11	CARBON		R539	1-215-373-31	METAL	
R362	1-215-883-11	METAL OXIDE		R540	1-249-408-11	CARBON	
R363	1-249-422-11	CARBON		R541	1-249-427-11	CARBON	
R364	1-249-420-11	CARBON		R542	1-249-423-11	CARBON	
R366	1-249-430-11	CARBON		R543	1-249-430-11	CARBON	
R367	1-249-436-11	CARBON		R544	1-249-425-11	CARBON	
R368	1-249-427-11	CARBON		R545	1-247-750-11	CARBON	
R371	1-249-429-11	CARBON		R546	1-249-417-11	CARBON	
R397	1-249-434-11	CARBON		R547	1-249-429-11	CARBON	
R398	1-249-423-11	CARBON		R548	1-249-496-11	CARBON	
R401	1-249-409-11	CARBON		R549	1-249-415-11	CARBON	
R402	1-249-438-11	CARBON		R550	1-249-431-11	CARBON	
R403	1-249-438-11	CARBON		R551	1-249-431-11	CARBON	
R404	1-249-437-11	CARBON		R552	1-249-414-11	CARBON	
R405	1-249-438-11	CARBON		R554	1-249-427-11	CARBON	
R406	1-249-405-11	CARBON		R555	1-249-413-11	CARBON	
R409	1-249-441-11	CARBON					

A C

Les composants identifiés par une trame et une marque  $\Delta$  sont critiques pour la sécurité. Ne les remplacer que par une pièce portant le numéro spécifique.

The components identified by shading and mark  $\Delta$  are critical for safety. Replace only with part number specified.

REF.NO.	PART NO.	DESCRIPTION	REMARK
R556	1-216-352-11	METAL OXIDE 1.8 5%	1W F
R557	1-249-419-11	CARBON 1.5K 5%	1/4W
R558	1-249-410-11	CARBON 270 5%	1/4W
R559	1-249-415-11	CARBON 680 5%	1/4W
R560	1-249-423-11	CARBON 3.3K 5%	1/4W
R561	1-249-496-11	CARBON 100K 5%	1/2W
R562	1-249-429-11	CARBON 10K 5%	1/4W
R563	1-249-436-11	CARBON 39K 5%	1/4W
R564	1-215-417-00	METAL 680 1%	1/6W
R565	1-249-425-11	CARBON 4.7K 5%	1/4W
R566	1-247-883-00	CARBON 150K 5%	1/4W
R567	1-216-380-11	METAL OXIDE 8.2 5%	2W F
R568	1-216-390-11	METAL OXIDE 1.2 5%	3W F
R569	1-214-913-00	METAL 100K 1%	1/2W
R570	1-215-898-11	METAL OXIDE 10K 5%	2W F
R571	1-216-356-00	METAL OXIDE 3.9 5%	1W F
R572	1-249-423-11	CARBON 3.3K 5%	1/4W
R575	1-249-401-11	CARBON 47 5%	1/4W
R577	1-216-451-11	METAL OXIDE 120 5%	2W F
R578	1-259-880-11	CARBON 2.2M 5%	1/4W
R579	$\Delta$ 1-249-415-91	CARBON 680 5%	1/4W F
R580	1-215-863-11	METAL OXIDE 100 5%	1W F
R581	1-249-417-11	CARBON 1K 5%	1/4W F
R582	1-215-863-11	METAL OXIDE 100 5%	1W F
R583	1-215-863-11	METAL OXIDE 100 5%	1W F
R586	1-247-746-11	CARBON 390 5%	1/2W
R587	$\Delta$ 1-215-870-91	METAL OXIDE 1.5K 5%	1W F
R589	1-249-441-11	CARBON 100K 5%	1/4W
R598	1-249-389-11	CARBON 4.7 5%	1/4W F
R599	1-249-417-11	CARBON 1K 5%	1/4W
R601	$\Delta$ 1-202-726-91	SOLID 3.9M 10%	1/2W
R602	$\Delta$ 1-205-792-11	WIREWOUND 1.8 5%	10W F
R603	1-247-889-00	CARBON 270K 5%	1/4W
R605	$\Delta$ 1-205-984-11	WIREWOUND 150 5%	20W
R610	$\Delta$ 1-217-224-11	WIREWOUND 100 10%	2W F
R611	1-215-872-11	METAL OXIDE 3.3K 5%	1W F
R612	1-205-986-11	WIREWOUND 4.7K 5%	20W
R613	1-249-437-11	CARBON 47K 5%	1/4W
R614	1-249-429-11	CARBON 10K 5%	1/4W
R615	$\Delta$ 1-216-463-91	METAL OXIDE 12K 5%	2W F
R616	$\Delta$ 1-247-719-91	CARBON 3.3K 5%	1/4W F
R617	1-249-401-11	CARBON 47 5%	1/4W F
R618	1-247-895-00	CARBON 470K 5%	1/4W

<VARIABLE RESISTOR>

RV131	1-238-012-11	RES, ADJ, CARBON 1K
RV201	1-238-016-11	RES, ADJ, CARBON 10K
RV306	1-238-016-11	RES, ADJ, CARBON 10K
RV307	1-238-011-11	RES, ADJ, CARBON 470
RV501	1-228-728-00	RES, ADJ, CERAMIC CARBON 100K
RV502	1-238-020-11	RES, ADJ, CARBON 100K
RV503	1-224-251-99	RES, ADJ, METAL GLAZE 4.7K
RV505	1-238-017-11	RES, ADJ, CARBON 22K
RV506	1-238-019-11	RES, ADJ, CARBON 47K
RV507	1-238-010-11	RES, ADJ, CARBON 330
RV508	1-238-012-11	RES, ADJ, CARBON 1K

<RELAY>

RY601  $\Delta$ 1-515-573-13 RELAY, POWER

<SWITCH>

REF.NO.	PART NO.	DESCRIPTION	REMARK
S101	$\Delta$ 1-571-532-23	SWITCH, TACTIL (POWER)	
S102	1-571-532-21	SWITCH, TACTIL	
S103	1-571-532-21	SWITCH, TACTIL	
S104	1-571-532-21	SWITCH, TACTIL	
S105	1-571-532-21	SWITCH, TACTIL	
S106	1-571-532-21	SWITCH, TACTIL	
<SPARK GAP>			
SG501	1-519-422-11	GAP, SPARK	
<TRANSFORMER>			
T261	$\Delta$ 1-427-479-11	TRANSFORMER (SOT)	
T501	1-437-195-11	TRANSFORMER, HORIZONTAL DRIVE	
T504	$\Delta$ 1-439-416-41	TRANSFORMER ASSY, FLYBACK (NX-1604)	
T599	$\Delta$ 1-421-857-11	TRANSFORMER, FERRITE	
T601	$\Delta$ 1-424-335-21	TRANSFORMER, LINE FILTER	
<THERMISTOR>			
THP601	$\Delta$ 1-808-081-14	THERMISTOR, POSITIVE	
<TUNER>			
TU101	$\Delta$ 1-465-371-11	TUNER, ET (BTP-RA401)	
<CRYSTAL>			
X101	1-577-082-11	VIBRATOR, CERAMIC	
X301	1-567-505-11	OSCILLATOR, CRYSTAL	
*****			
A-1331-126-A	C BOARD, COMPLETE	*****	
*1-506-371-00	PIN, CONNECTOR 2P		
*1-508-768-00	PIN, CONNECTOR (5MM PITCH) 6P		
1-540-071-11	SOCKET, PICTURE TUBE		
*1-564-509-11	PLUG, CONNECTOR 6P		
*4-379-160-01	COVER (REAR LID), CV		
*4-379-167-01	COVER (MAIN), CV		
<CAPACITOR>			
C701	1-136-601-11	FILM 0.01MF 10%	630V
C702	1-162-116-00	CERAMIC 680PF 10%	2KV
C704	1-124-915-11	ELECT 10MF 20%	63V
C705	1-102-116-00	CERAMIC 680PF 10%	50V
C706	1-102-116-00	CERAMIC 680PF 10%	50V
C707	1-102-116-00	CERAMIC 680PF 10%	50V
C708	1-102-110-00	CERAMIC 220PF 10%	50V
C709	1-102-110-00	CERAMIC 220PF 10%	50V
C710	1-102-110-00	CERAMIC 220PF 10%	50V
C712	1-124-477-11	ELECT 47MF 20%	16V
C722	1-162-622-11	CERAMIC 330PF 10%	6.3KV
<DIODE>			
D701	8-719-911-19	DIODE 1SS119	
D702	8-719-911-19	DIODE 1SS119	

The components identified by shading and mark  $\Delta$  are critical for safety. Replace only with part number specified.

Les composants identifiés par une trame et une marque  $\Delta$  sont critiques pour la sécurité. Ne les remplacer que par une pièce portant le numéro spécifié.

C

REF. NO.	PART NO.	DESCRIPTION	REMARK	REF. NO.	PART NO.	DESCRIPTION	REMARK
D703	8-719-911-19	DIODE ISS119		*****			
		<COIL>		MISCELLANEOUS			
L701	1-408-417-00	INDUCTOR 47UH		*****			
		<TRANSISTOR>		$\Delta$ 1-426-358-11 COIL, DEMAGNETIZATION $\Delta$ 1-451-268-11 DEFLECTION YOKE (Y21PXA) 1-452-032-00 MAGNET, DISK; 10MM $\phi$ 1-452-094-00 MAGNET, ROTATABLE DISK; 15MM $\phi$ 1-452-277-00 MAGNET, BMC $\Delta$ 1-536-678-31 ANTENNA BLOCK (KV-20TR22(U), KV-20TS27(U) ONLY) $\Delta$ 1-537-077-21 ANTENNA BLOCK (KV-20TS27(C) ONLY) 1-544-283-11 SPEAKER $\Delta$ 1-590-492-11 CORD, POWER (WITH CONNECTOR)			
Q701	8-729-423-37	TRANSISTOR 2SC3311A-QRS		V901	$\Delta$ 8-738-752-05	PICTURE TUBE (A51JUH50X)	
Q702	$\Delta$ 8-729-326-11	TRANSISTOR 2SC2611		*****			
Q703	8-729-423-37	TRANSISTOR 2SC3311A-QRS		ACCESSORIES AND PACKING MATERIALS			
Q704	8-729-326-11	TRANSISTOR 2SC2611		*****			
Q705	8-729-423-37	TRANSISTOR 2SC3311A-QRS		PART NO. DESCRIPTION REMARK ----- 1-501-372-41 ANTENNA, TELESCOPIC 1-513-379-00 CONVERTER (EAC-25) (KV-20TS27(C) ONLY) 1-562-443-11 CONNECTOR, ANTENNA (KV-20TR22(U), KV-20TS27(U) ONLY) 3-752-986-21 MANUAL, INSTRUCTION 3-752-986-31 MANUAL, INSTRUCTION (KV-20TS27(C) ONLY) *4-030-589-01 INDIVIDUAL CARTON *4-030-606-01 CUSHION (UPPER) (ASSY) *4-030-607-01 CUSHION (LOWER) (ASSY) *4-380-340-01 BAG, PROTECTION			
Q706	8-729-326-11	TRANSISTOR 2SC2611		REMOTE COMMANDER 1-465-385-11 REMOTE COMMANDER (RM-781) (KV-20TR22(U) ONLY) 1-465-387-11 REMOTE COMMANDER (RM-783) (KV-20TS27(U/C) ONLY) 4-394-031-01 COVER, BATTERY (FOR RM-781, RM-783)			
		<RESISTOR>		*****			
R701	1-202-838-00	SOLID 100K 10% 1/2W		*****			
R702	1-216-393-00	METAL OXIDE 2.2 5% 3W F		*****			
R703	1-202-842-11	SOLID 220K 10% 1/2W		*****			
R704	1-202-846-00	SOLID 470K 10% 1/2W		*****			
R705	1-202-837-00	SOLID 82K 10% 1/2W		*****			
R706	1-202-549-00	SOLID 100 10% 1/2W		*****			
R707	1-202-842-11	SOLID 220K 10% 1/2W		*****			
R708	1-202-824-00	SOLID 3.3K 10% 1/2W		*****			
R709	1-202-824-00	SOLID 3.3K 10% 1/2W		*****			
R710	1-202-549-00	SOLID 100 10% 1/2W		*****			
R711	1-249-411-11	CARBON 330 5% 1/4W		*****			
R712	1-249-411-11	CARBON 330 5% 1/4W		*****			
R713	1-202-824-00	SOLID 3.3K 10% 1/2W		*****			
R714	1-249-421-11	CARBON 2.2K 5% 1/4W		*****			
R715	1-249-422-11	CARBON 2.7K 5% 1/4W		*****			
R716	1-249-414-11	CARBON 560 5% 1/4W		*****			
R718	1-249-417-11	CARBON 1K 5% 1/4W		*****			
R719	1-249-420-11	CARBON 1.8K 5% 1/4W		*****			
R720	1-249-414-11	CARBON 560 5% 1/4W		*****			
R722	1-215-924-00	METAL OXIDE 15K 5% 3W F		*****			
R723	1-249-413-11	CARBON 470 5% 1/4W		*****			
R725	1-249-421-11	CARBON 2.2K 5% 1/4W		*****			
R726	1-249-417-11	CARBON 1K 5% 1/4W		*****			
R727	1-249-419-11	CARBON 1.5K 5% 1/4W		*****			
R728	1-249-413-11	CARBON 470 5% 1/4W		*****			
R729	1-249-411-11	CARBON 330 5% 1/4W		*****			
R730	1-215-924-00	METAL OXIDE 15K 5% 3W F		*****			
R732	1-247-818-11	CARBON 300 5% 1/4W		*****			
R733	1-249-422-11	CARBON 2.7K 5% 1/4W		*****			
R734	1-249-421-11	CARBON 2.2K 5% 1/4W		*****			
R735	1-249-417-11	CARBON 1K 5% 1/4W		*****			
R737	1-215-924-00	METAL OXIDE 15K 5% 3W F		*****			
R738	1-202-848-00	SOLID 680K 10% 1/2W		*****			
R739	1-202-838-00	SOLID 100K 10% 1/2W		*****			
R740	1-202-842-11	SOLID 220K 10% 1/2W		*****			
		<VARIABLE RESISTOR>		*****			
RV701	$\Delta$ 1-230-619-11	RES, ADJ, METAL GLAZE 110W		*****			
RV702	1-228-993-00	RES, ADJ, CARBON 4.7K		*****			
RV703	1-228-991-00	RES, ADJ, CARBON 2.2K		*****			
RV704	1-228-993-00	RES, ADJ, CARBON 4.7K		*****			
RV705	1-228-991-00	RES, ADJ, CARBON 2.2K		*****			
RV706	1-228-993-00	RES, ADJ, CARBON 4.7K		*****			
RV707	1-228-995-00	RES, ADJ, CARBON 22K		*****			
RV708	1-230-641-11	RES, ADJ, METAL GLAZE 2.2M		*****			